

Einbauanleitung (TECE)
Mounting instruction
Montagehandleiding
Instructions de montage
Istruzioni di montaggio

Poresta® BFR Universalrinnenboard
 Poresta® BFR Universal Grooved Board
 Poresta® BFR universeel goot-board
 Lambris intérieur universel Poresta® BFR
 Piastra scanalata universale Poresta® BFR

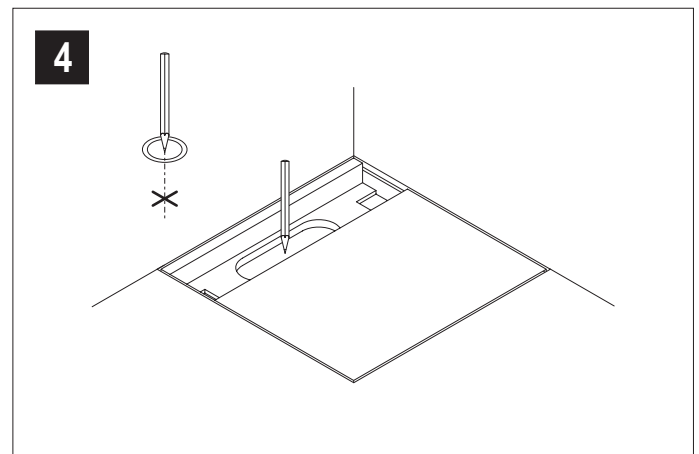
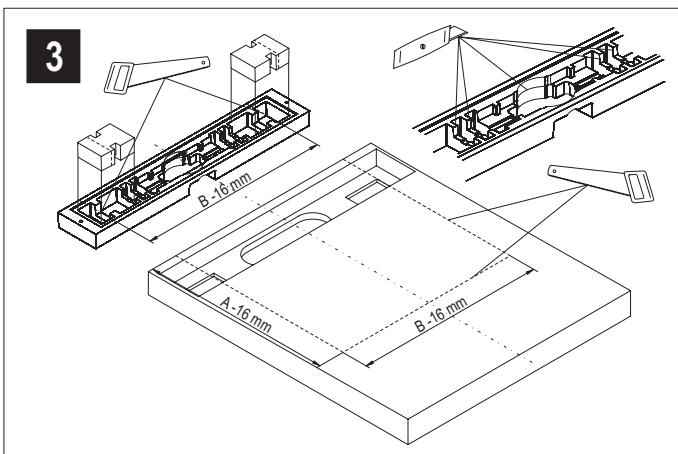
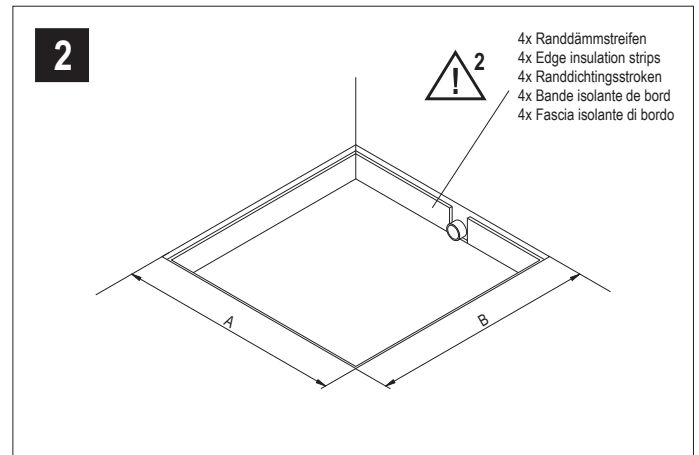
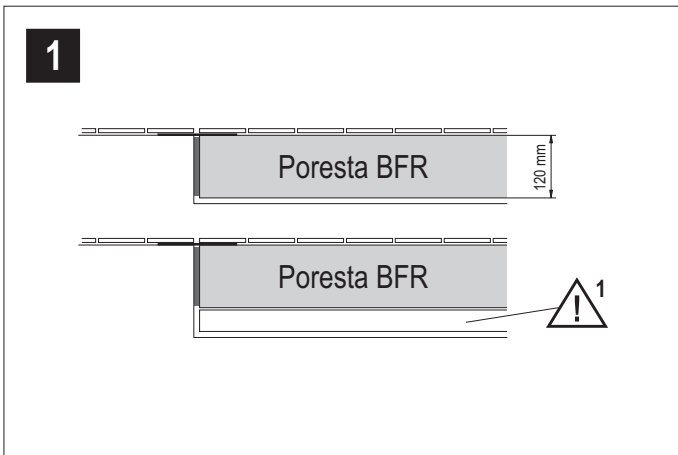
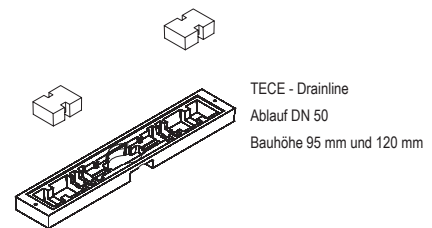
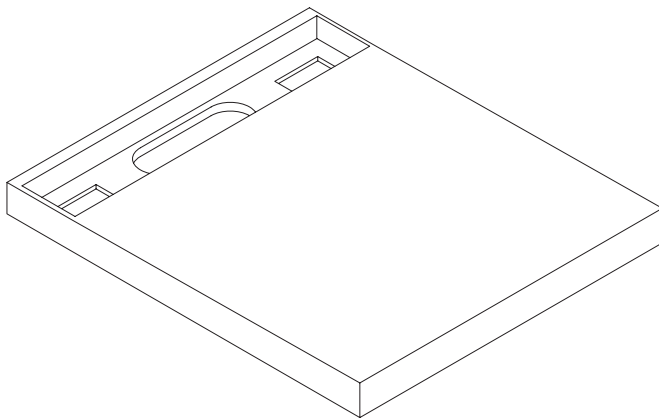

Einbauanleitung (TECE)
Mounting instruction
Montagehandleiding
Instructions de montage
Istruzioni di montaggio

Poresta® BFR Universalrinnenboard
 Poresta® BFR Universal Grooved Board
 Poresta® BFR universeel goot-board
 Lambris intérieur universel Poresta® BFR
 Piastra scanalata universale Poresta® BFR

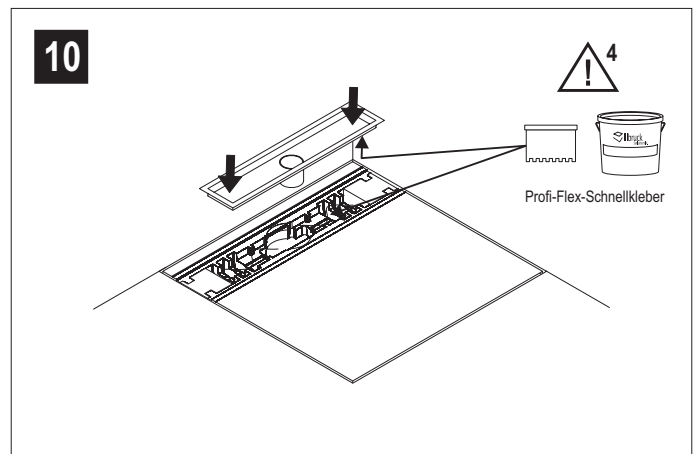
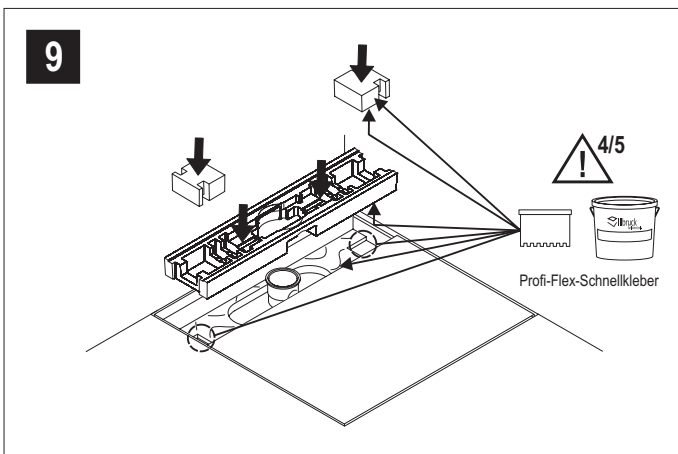
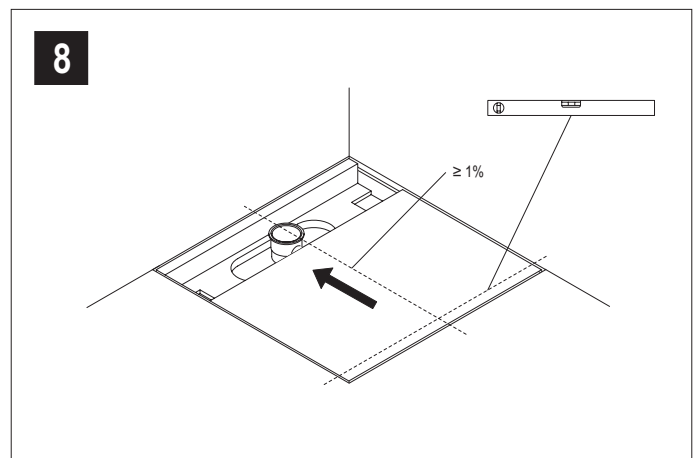
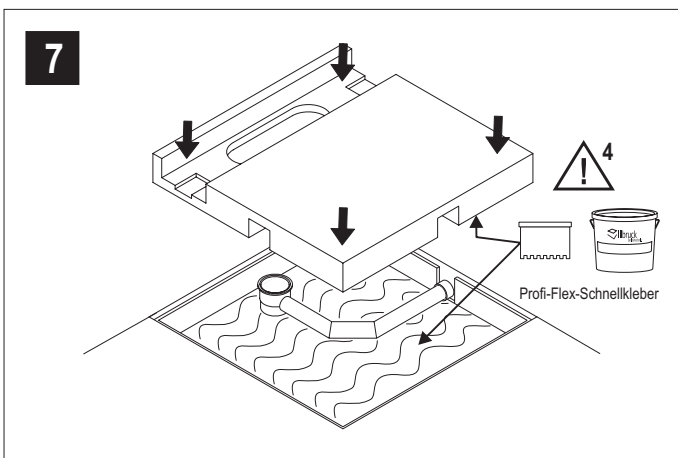
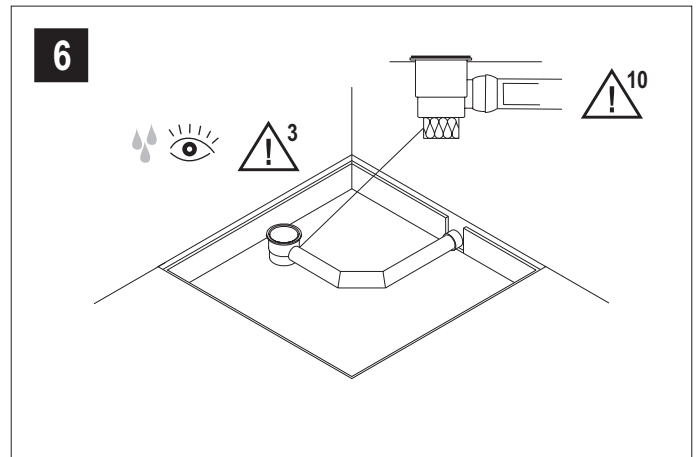
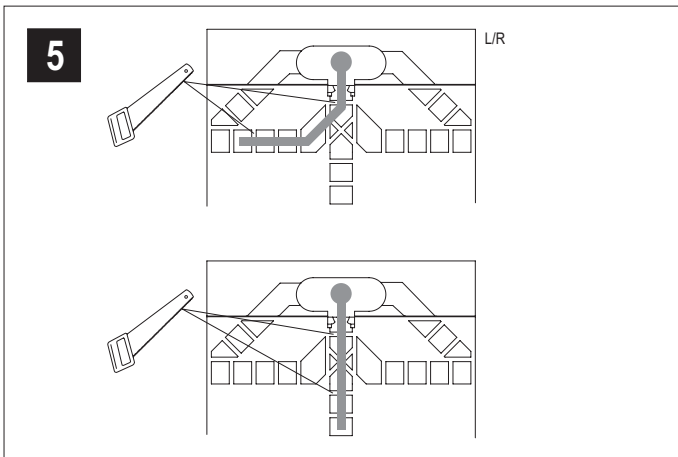

Einbauanleitung (Viega)
 Mounting instruction
 Montagehandleiding
 Instructions de montage
 Istruzioni di montaggio

Poresta® BFR Universalrinnenboard
 Poresta® BFR Universal Grooved Board
 Poresta® BFR universeel goot-board
 Lambris intérieur universel Poresta® BFR
 Piastra scanalata universale Poresta® BFR

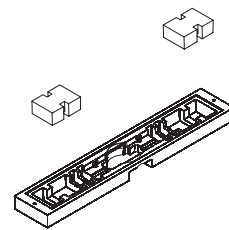
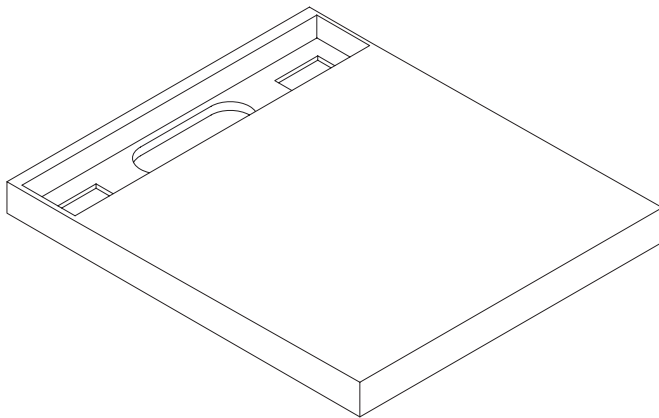

Viega - Advantix Duschrinne
 Viega - Advantix Duschrinne Basic
 Viega - Advantix Duschrinne Basic Wand

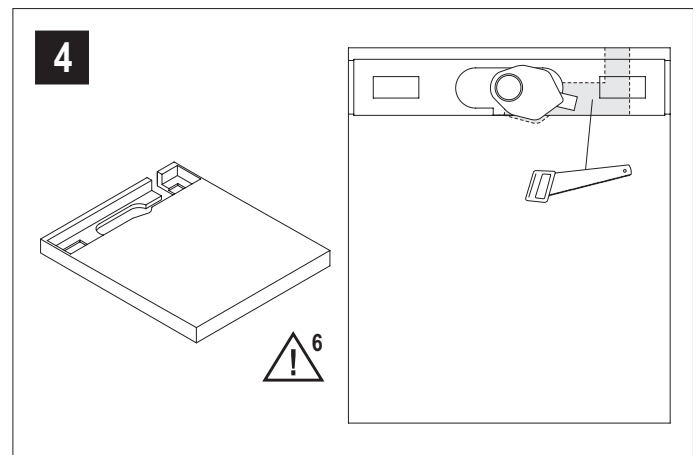
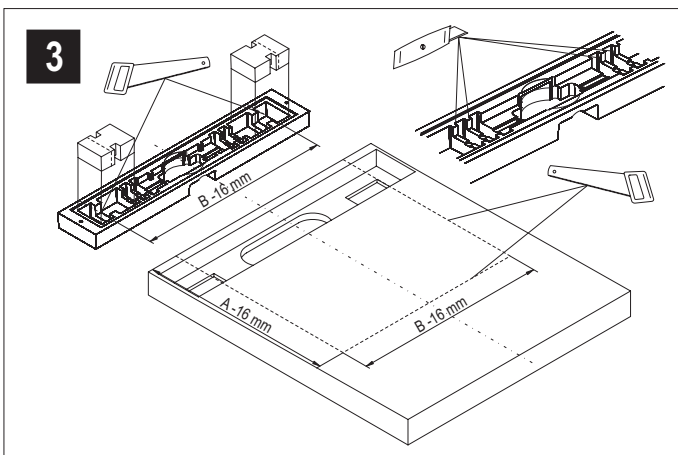
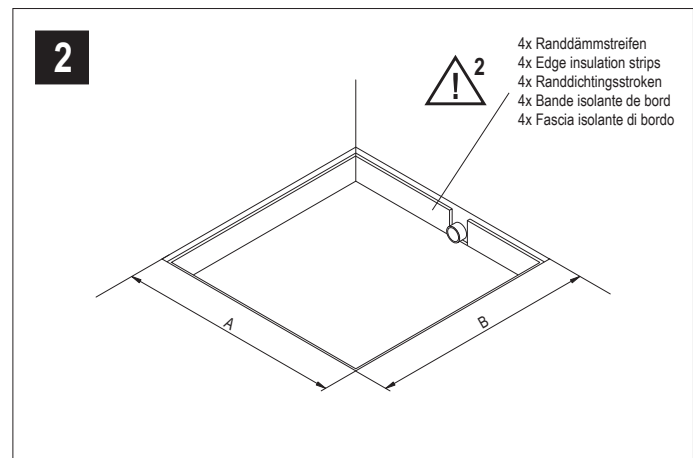
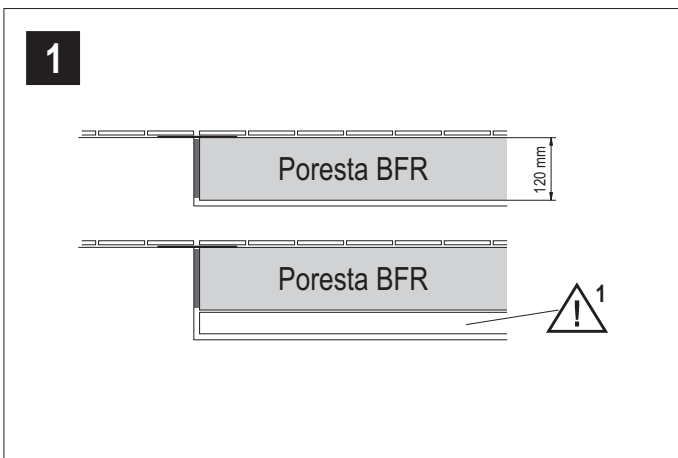

Einbauanleitung (Viega)
Mounting instruction
Montagehandleiding
Instructions de montage
Istruzioni di montaggio

Poresta® BFR Universalrinnenboard
 Poresta® BFR Universal Grooved Board
 Poresta® BFR universeel goot-board
 Lambris intérieur universel Poresta® BFR
 Piastra scanalata universale Poresta® BFR

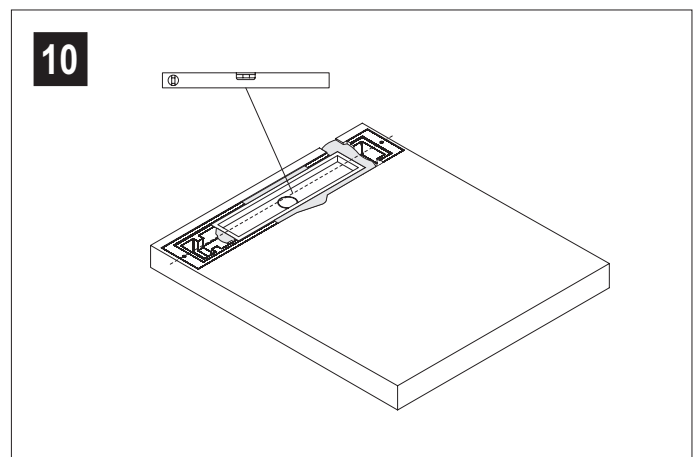
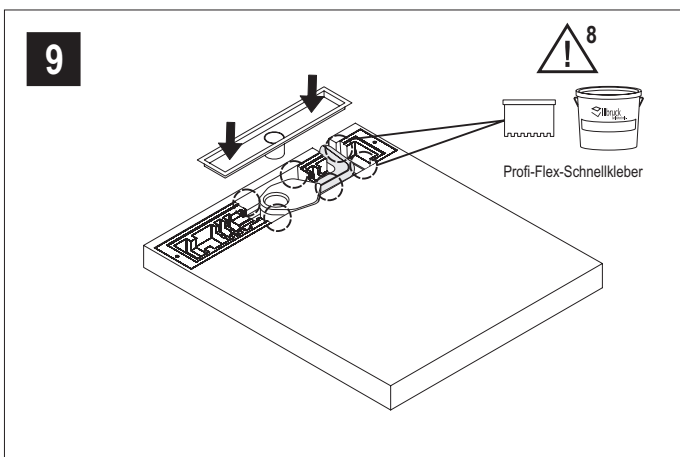
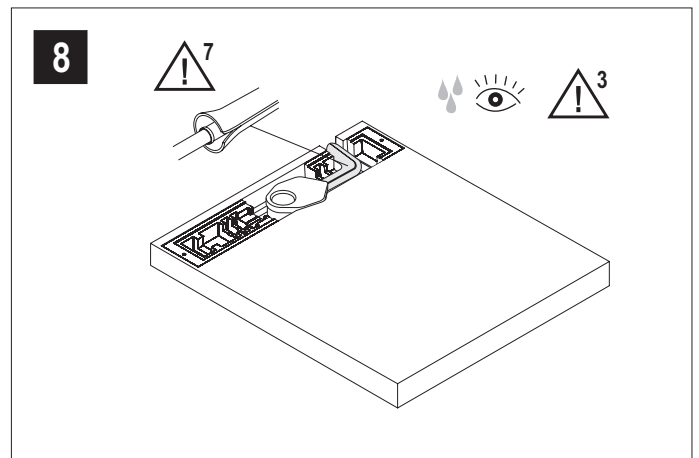
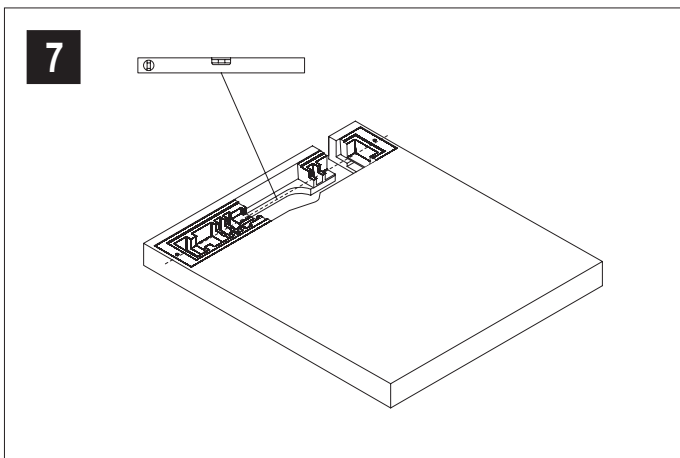
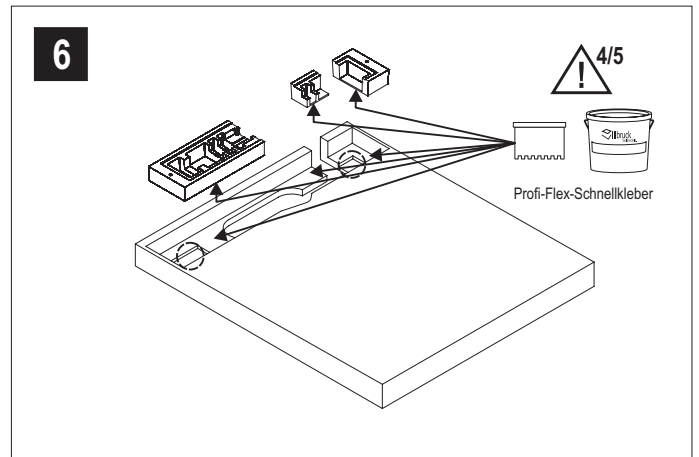
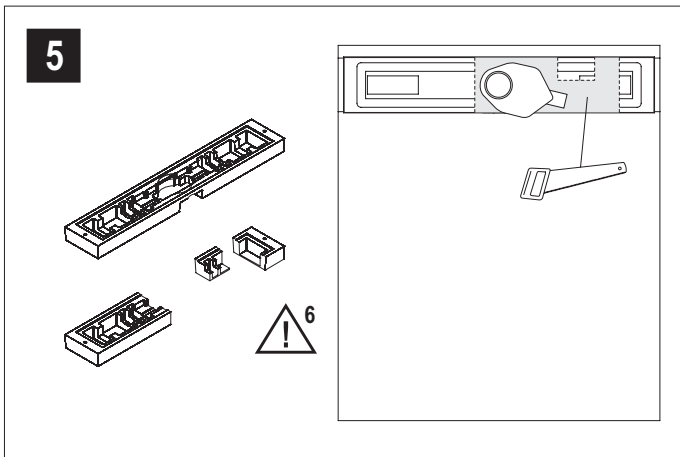

Einbauanleitung (Viega)
Mounting instruction
Montagehandleiding
Instructions de montage
Istruzioni di montaggio

Poresta® BFR Universalrinnenboard
Poresta® BFR Universal Grooved Board
Poresta® BFR universeel goot-board
Lambris intérieur universel Poresta® BFR
Piastra scanalata universale Poresta® BFR

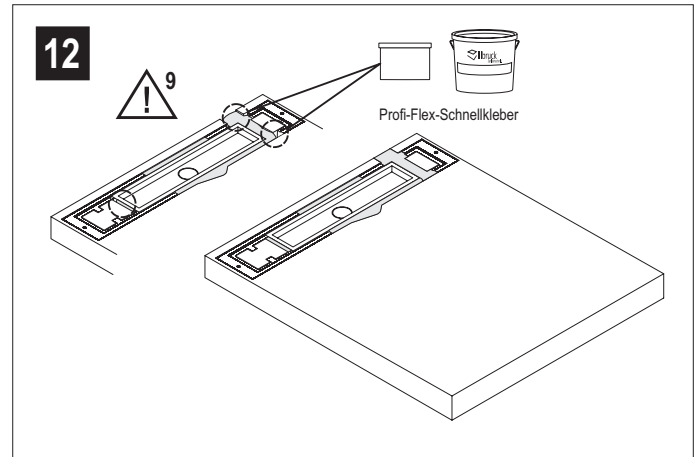
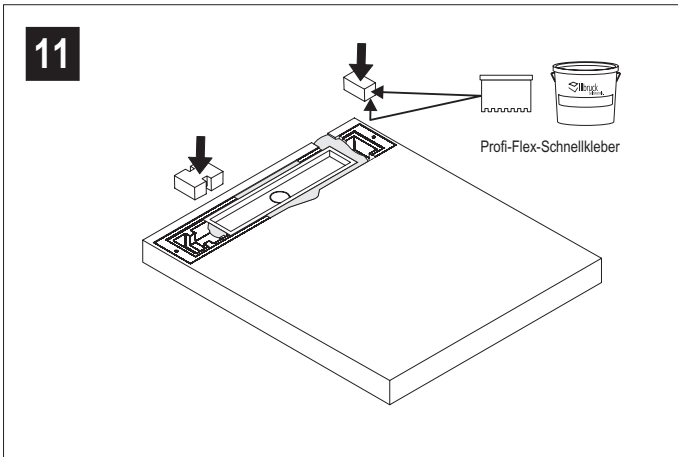

Einbauanleitung (ACO)
Mounting instruction
Montagehandleiding
Instructions de montage
Istruzioni di montaggio

Poresta® BFR Universalrinnenboard
 Poresta® BFR Universal Grooved Board
 Poresta® BFR universeel goot-board
 Lambris intérieur universel Poresta® BFR
 Piastra scanalata universale Poresta® BFR

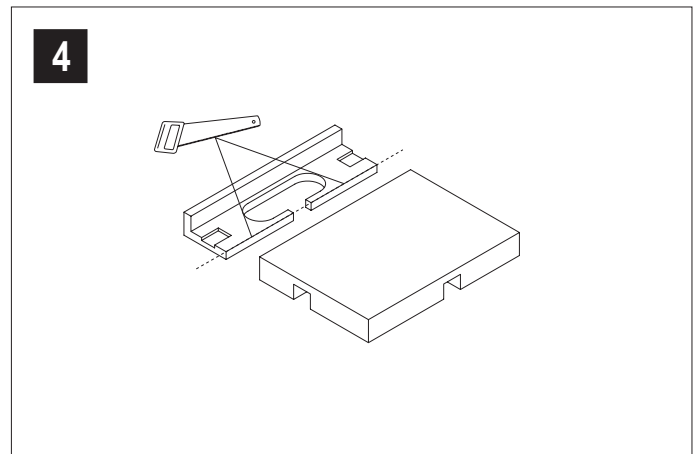
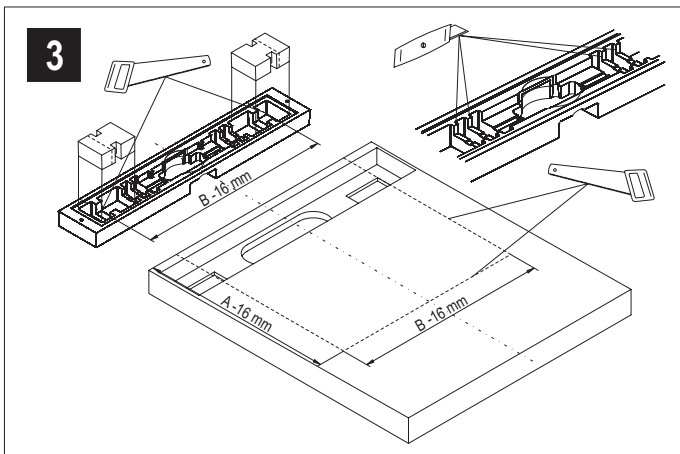
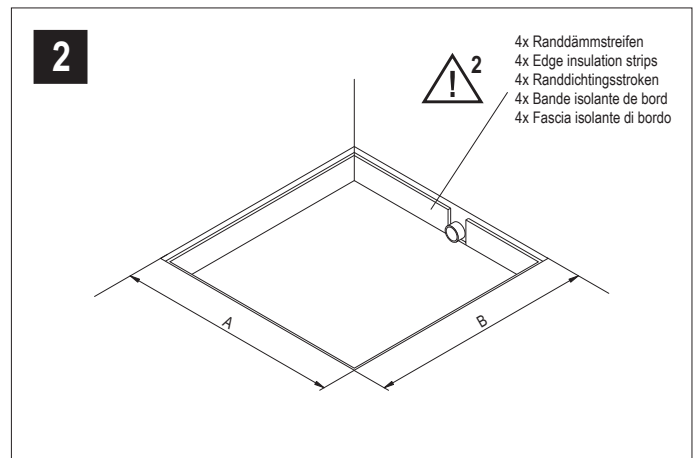
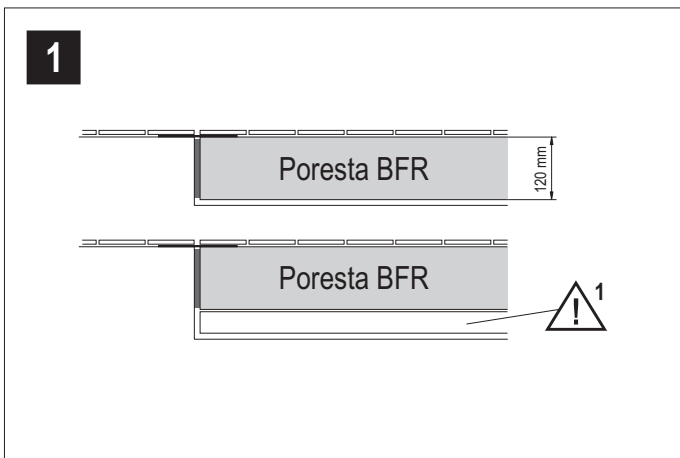
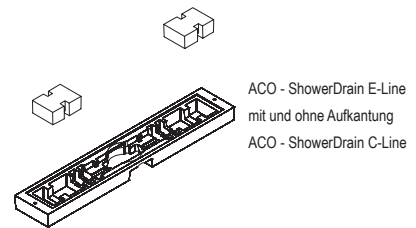
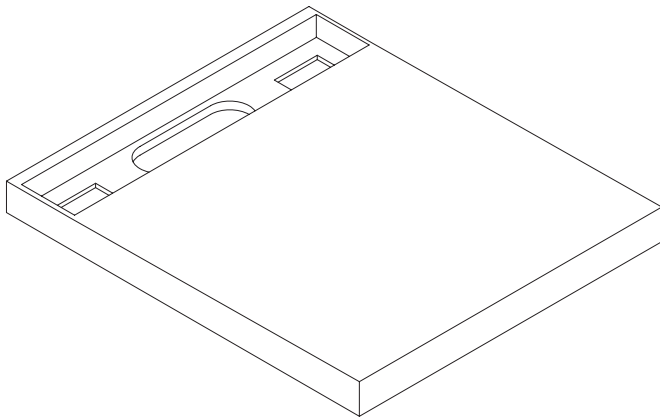

Einbauanleitung (ACO)
Mounting instruction
Montagehandleiding
Instructions de montage
Istruzioni di montaggio

Poresta® BFR Universalrinnenboard
 Poresta® BFR Universal Grooved Board
 Poresta® BFR universeel goot-board
 Lambris intérieur universel Poresta® BFR
 Piastra scanalata universale Poresta® BFR

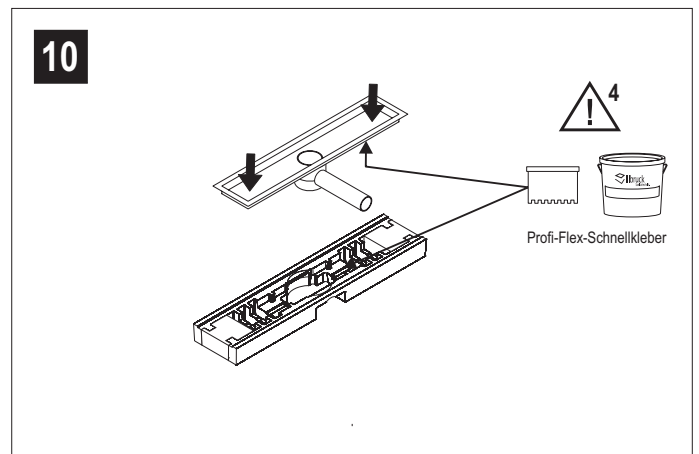
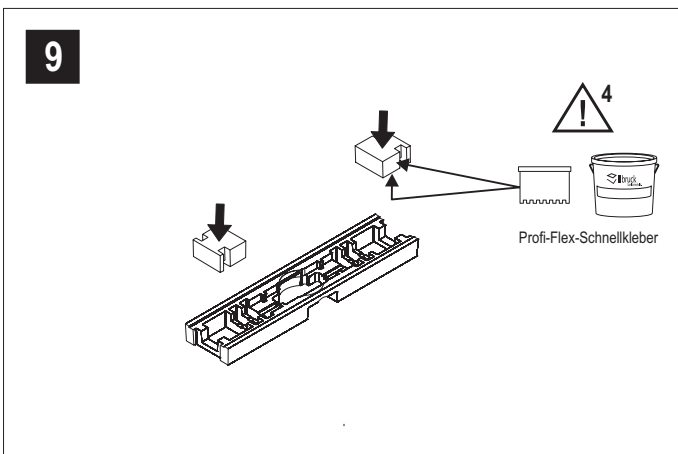
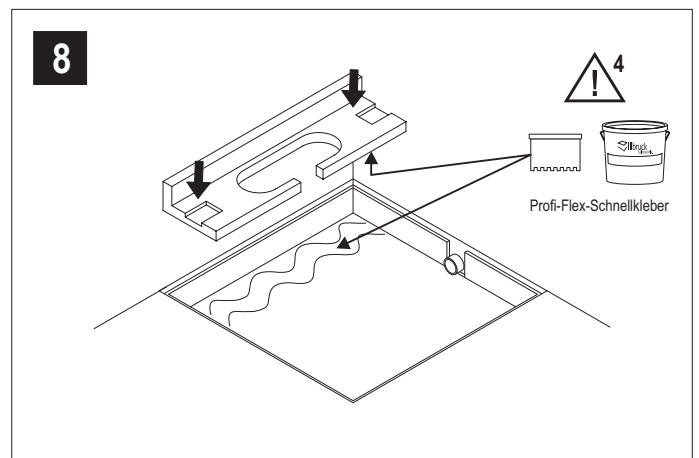
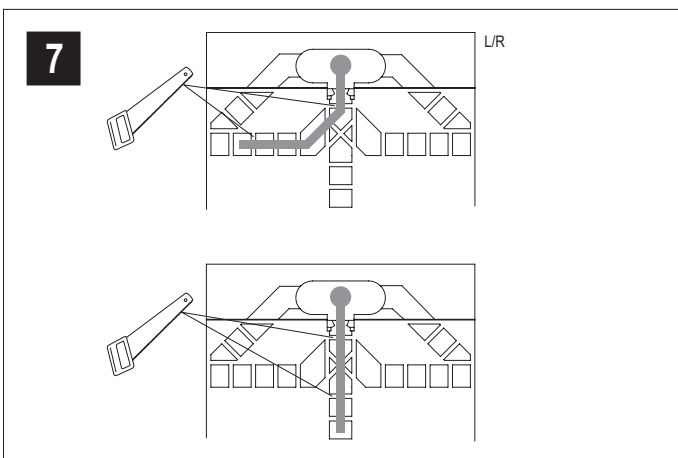
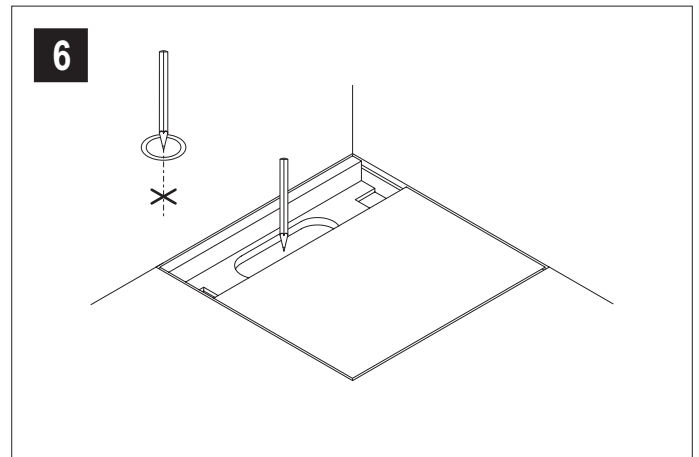
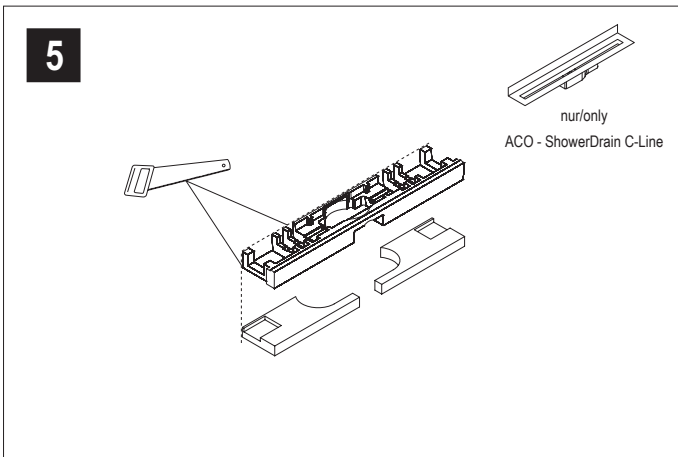

Einbauanleitung (ACO)
Mounting instruction
Montagehandleiding
Instructions de montage
Istruzioni di montaggio

Poresta® BFR Universalrinnenboard
 Poresta® BFR Universal Grooved Board
 Poresta® BFR universeel goot-board
 Lambris intérieur universel Poresta® BFR
 Piastra scanalata universale Poresta® BFR

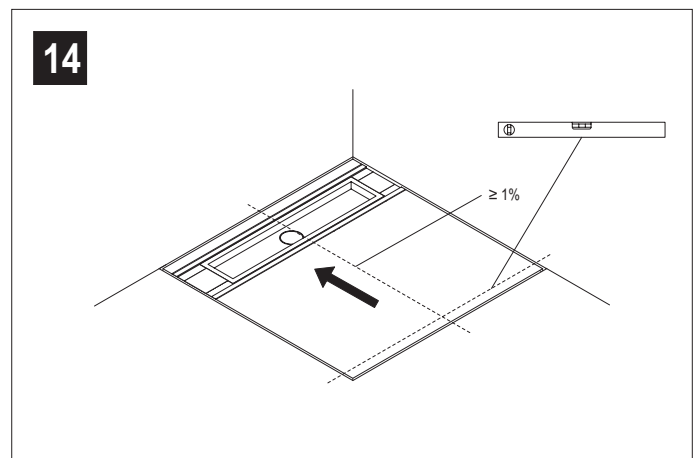
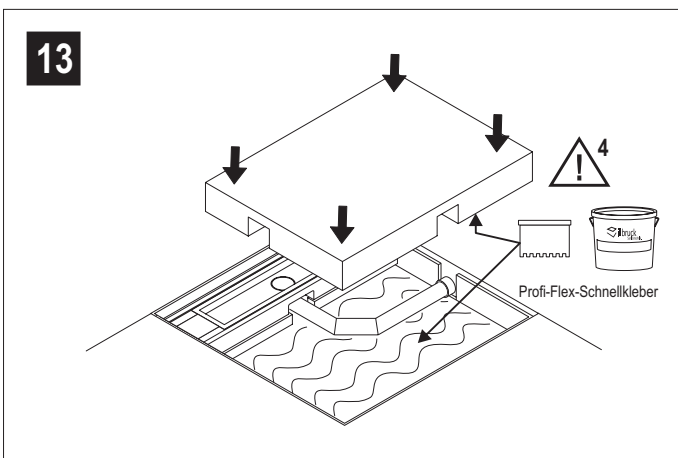
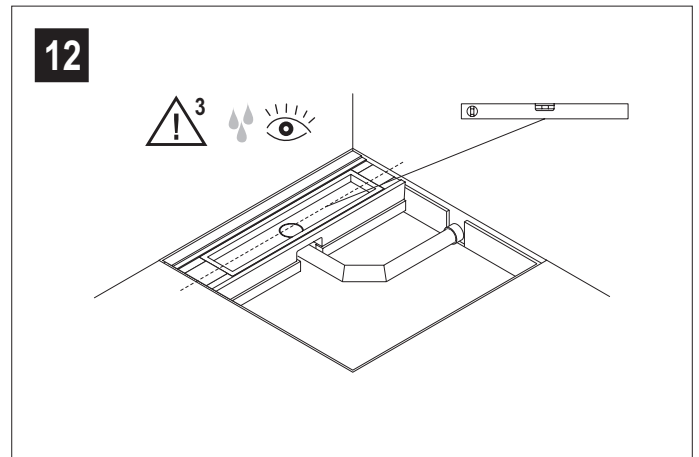
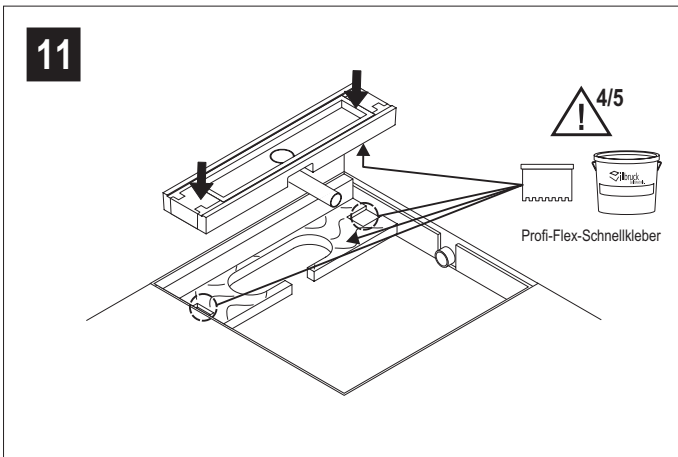

Einbauanleitung (ESS, Sanit)
 Mounting instruction
 Montagehandleiding
 Instructions de montage
 Istruzioni di montaggio

Poresta® BFR Universalrinnenboard
 Poresta® BFR Universal Grooved Board
 Poresta® BFR universeel goot-board
 Lambris intérieur universel Poresta® BFR
 Piastra scanalata universale Poresta® BFR

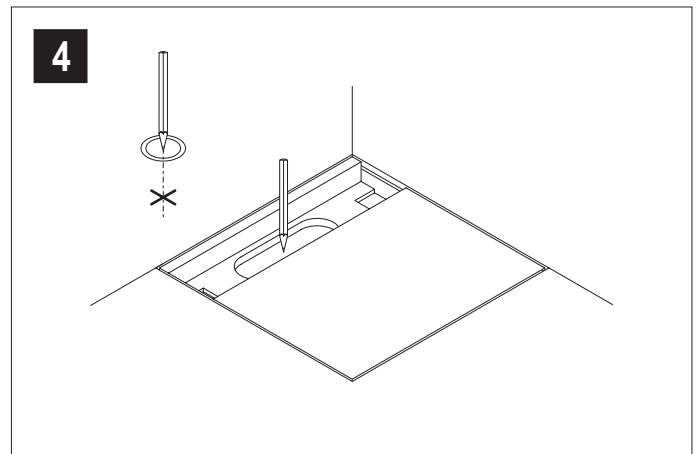
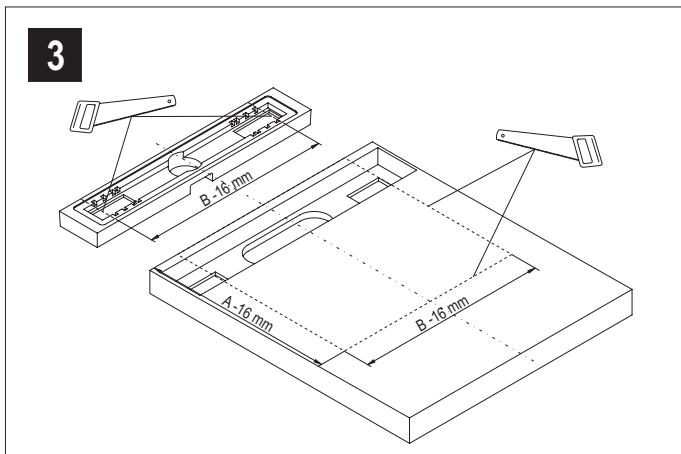
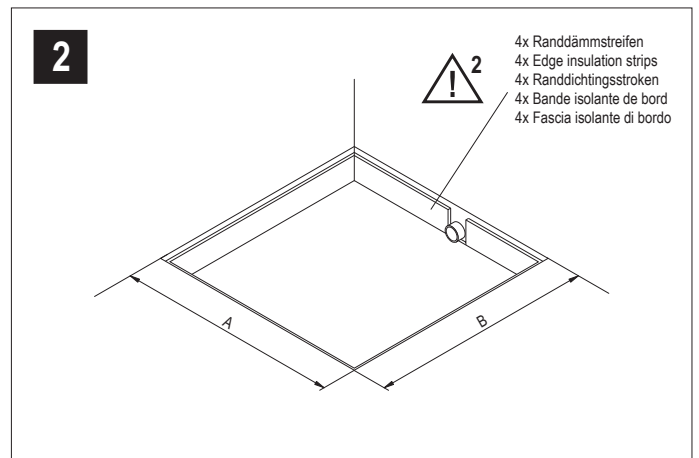
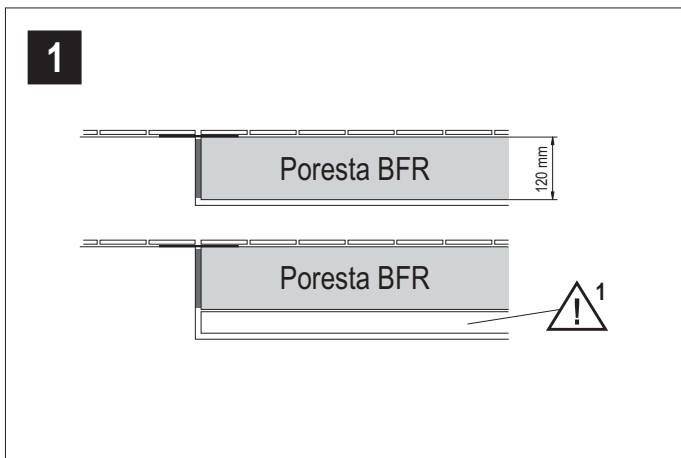
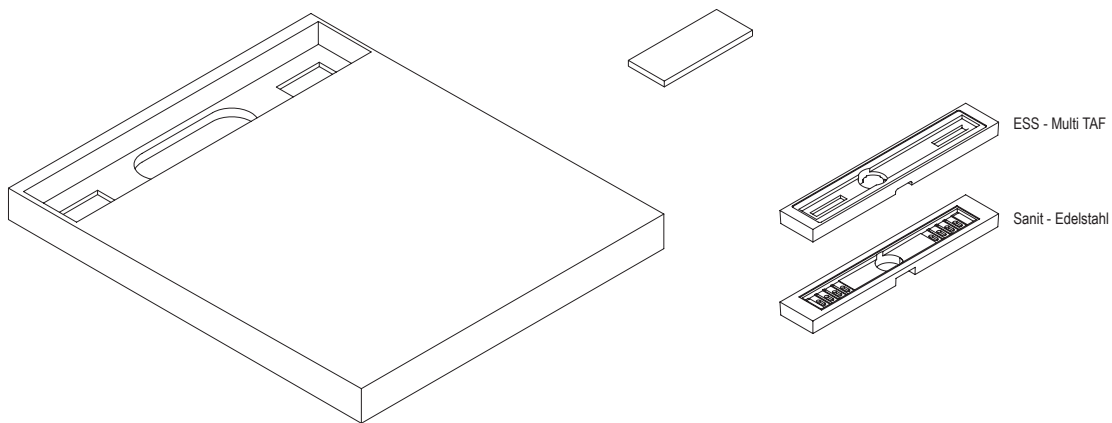

Einbauanleitung (ESS, Sanit)
Mounting instruction
Montagehandleiding
Instructions de montage
Istruzioni di montaggio

Poresta® BFR Universalrinnenboard
 Poresta® BFR Universal Grooved Board
 Poresta® BFR universeel goot-board
 Lambris intérieur universel Poresta® BFR
 Piastra scanalata universale Poresta® BFR

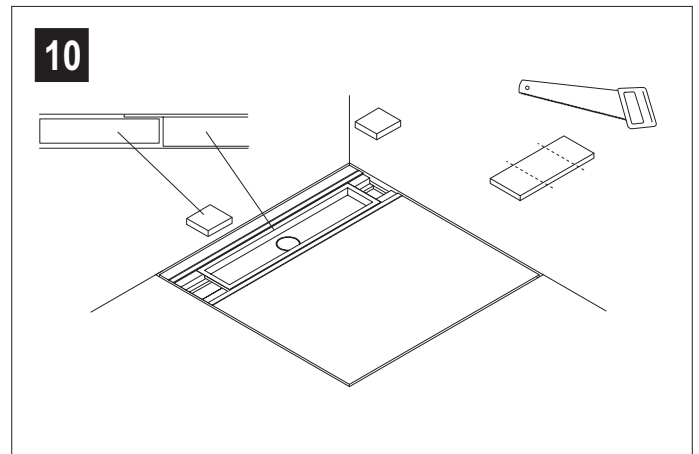
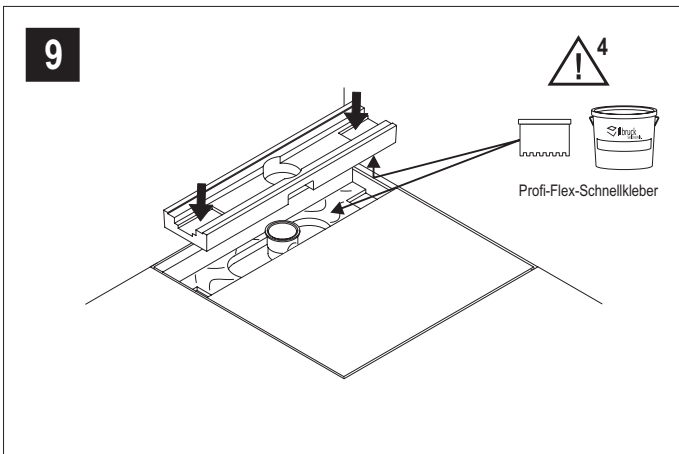
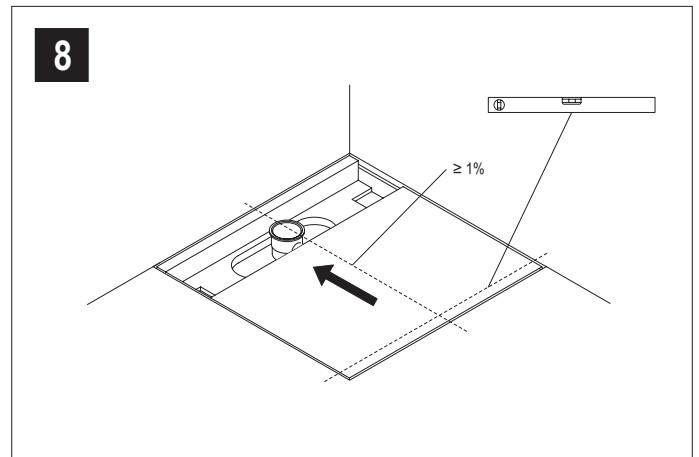
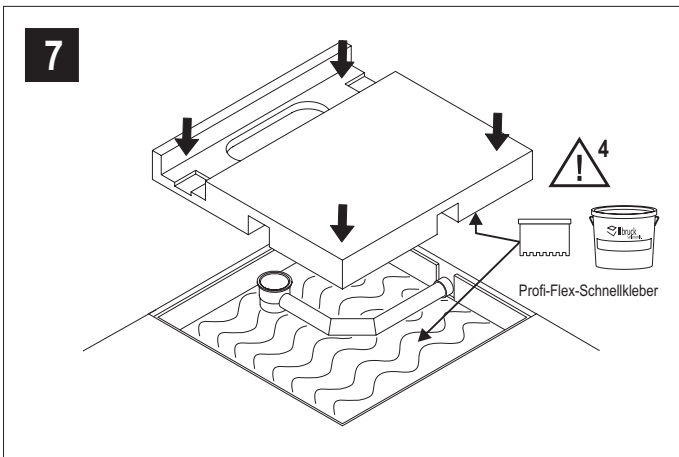
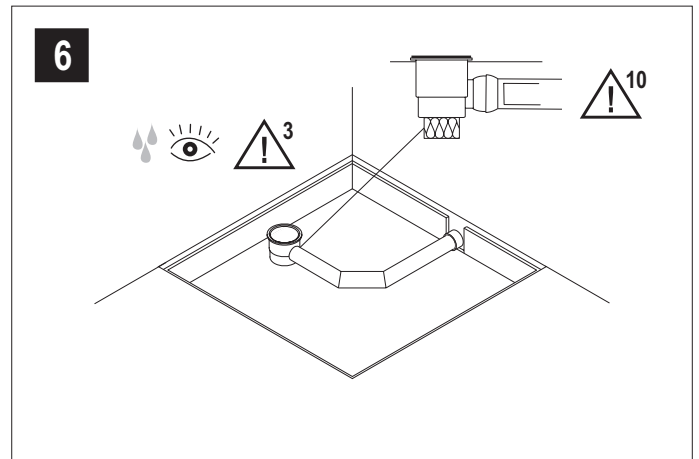
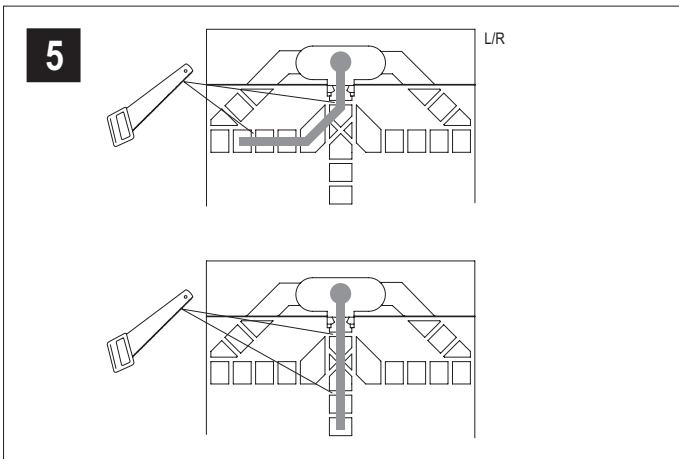

Einbauanleitung (ESS, Sanit)
Mounting instruction
Montagehandleiding
Instructions de montage
Istruzioni di montaggio

Poresta® BFR Universalrinnenboard
 Poresta® BFR Universal Grooved Board
 Poresta® BFR universeel goot-board
 Lambris intérieur universel Poresta® BFR
 Piastra scanalata universale Poresta® BFR

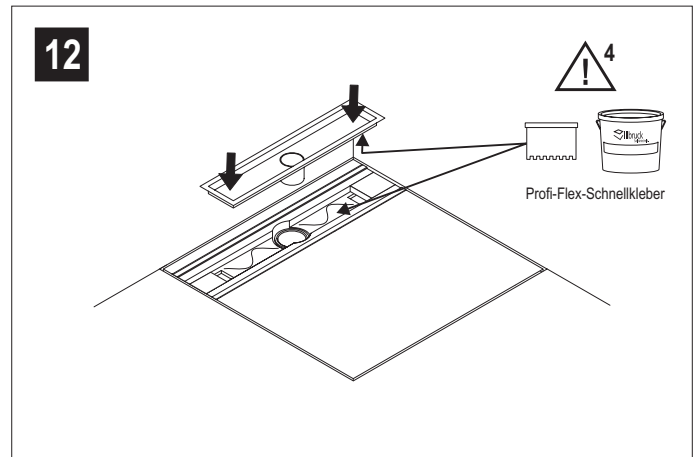
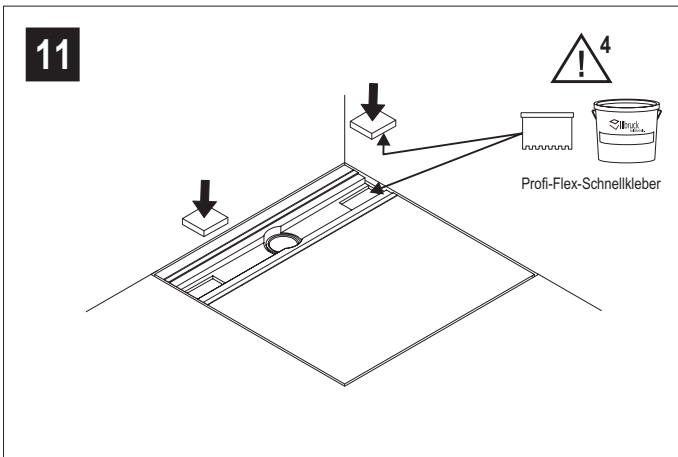

Einbauanleitung (Dallmer)
Mounting instruction
Montagehandleiding
Instructions de montage
Istruzioni di montaggio

Poresta® BFR Universalrinnenboard
 Poresta® BFR Universal Grooved Board
 Poresta® BFR universeel goot-board
 Lambris intérieur universel Poresta® BFR
 Piastra scanalata universale Poresta® BFR

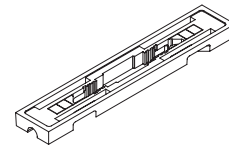
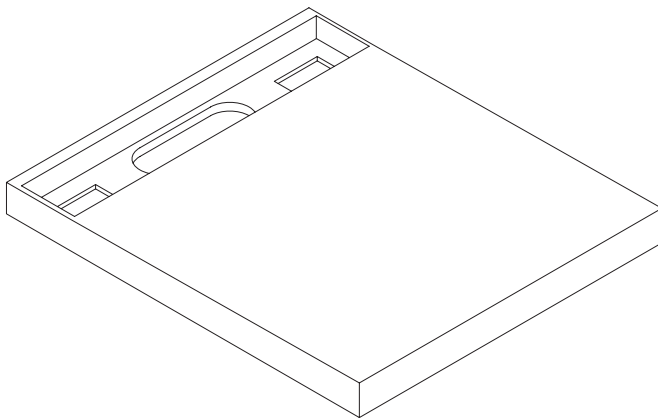

Dallmer - CeraLine F + W
 Dallmer - CeraLine F + W Plan

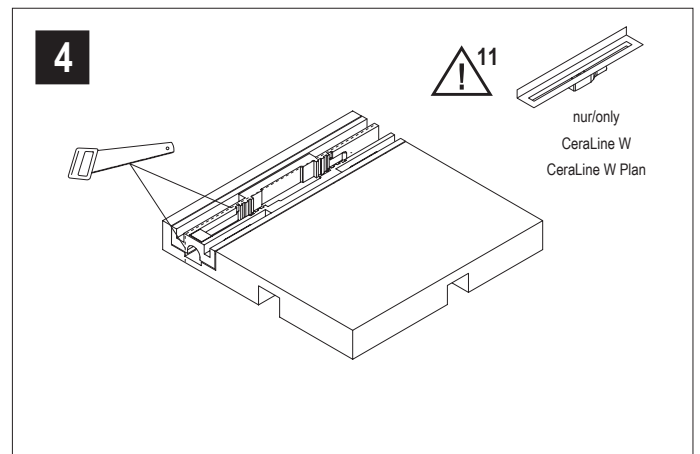
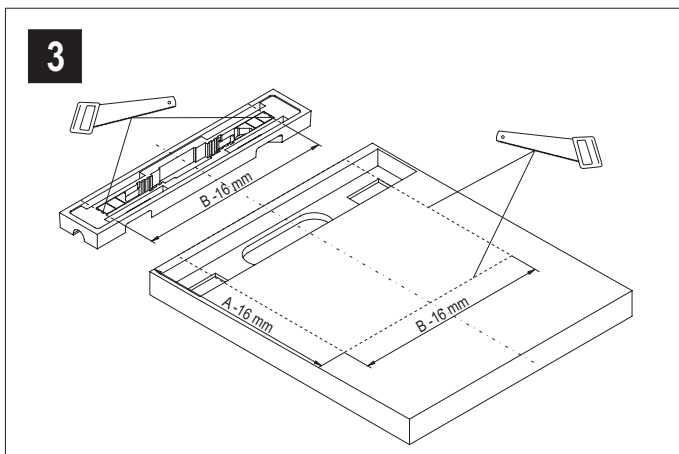
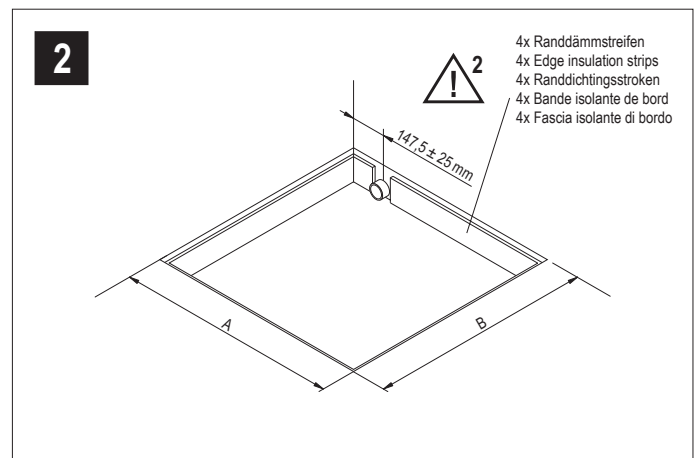
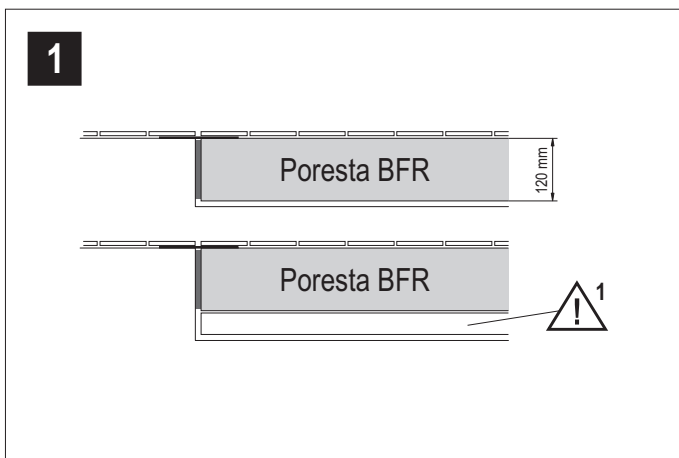

Einbauanleitung (Dallmer)
Mounting instruction
Montagehandleiding
Instructions de montage
Istruzioni di montaggio

Poresta® BFR Universalrinnenboard
 Poresta® BFR Universal Grooved Board
 Poresta® BFR universeel goot-board
 Lambris intérieur universel Poresta® BFR
 Piastra scanalata universale Poresta® BFR

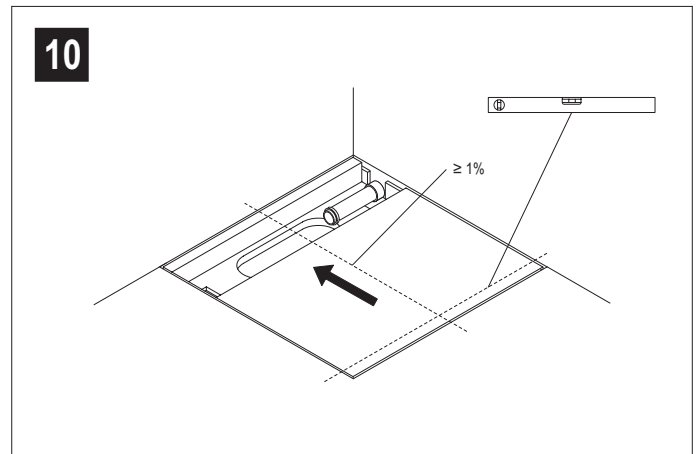
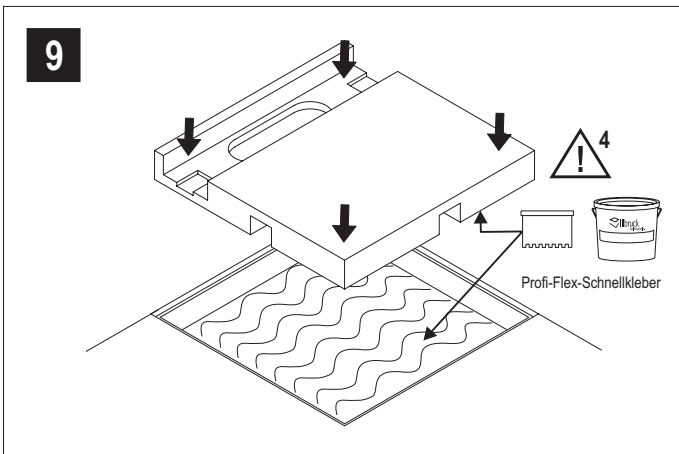
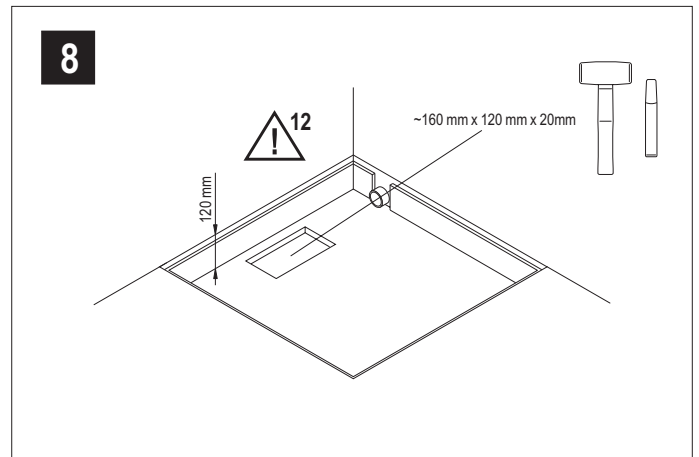
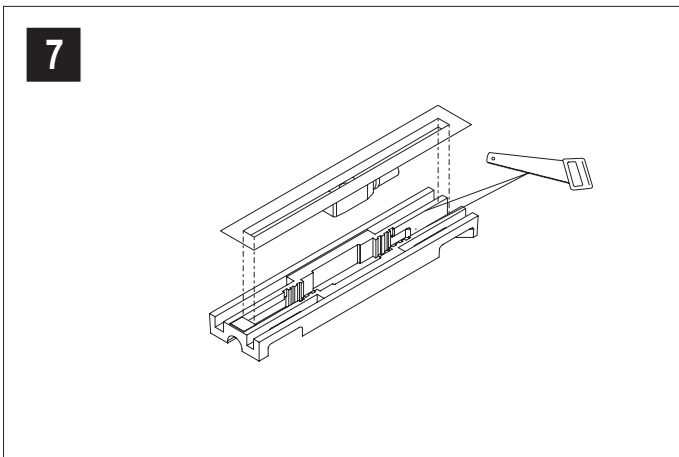
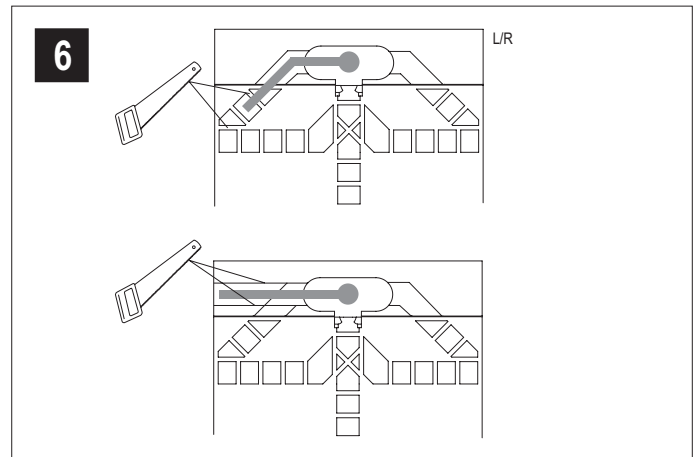
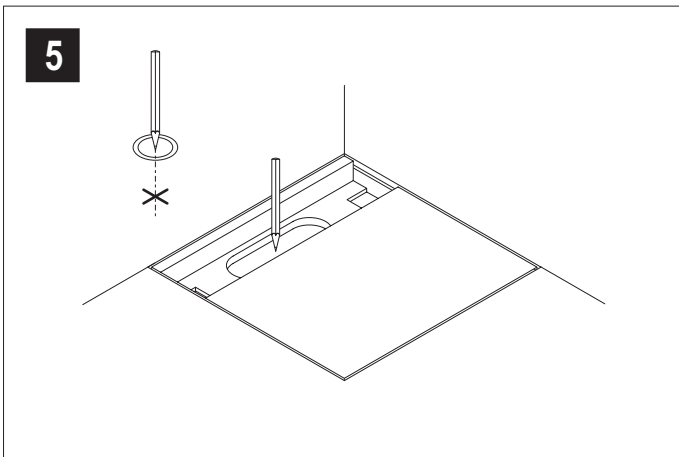

Einbauanleitung (Dallmer)
Mounting instruction
Montagehandleiding
Instructions de montage
Istruzioni di montaggio

Poresta® BFR Universalrinnenboard
Poresta® BFR Universal Grooved Board
Poresta® BFR universeel goot-board
Lambris intérieur universel Poresta® BFR
Piastra scanalata universale Poresta® BFR

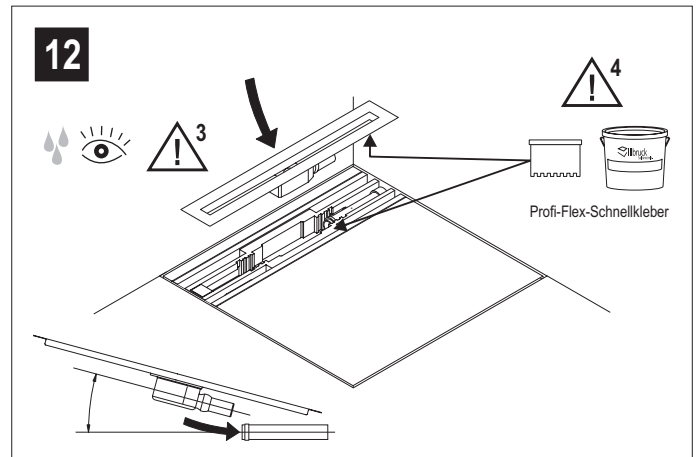
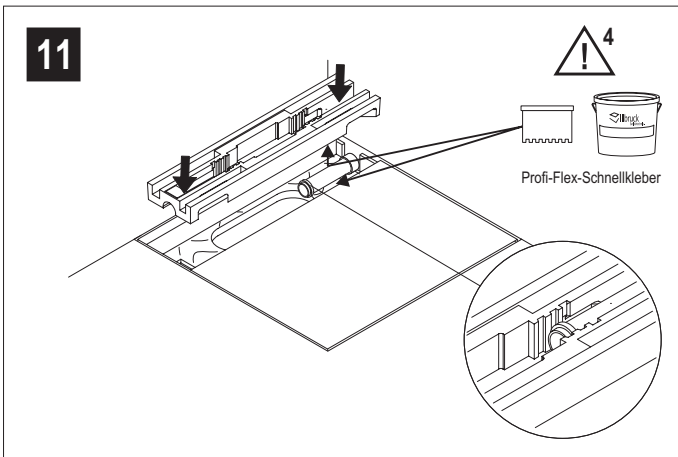

Einbauanleitung

Mounting instruction

Montagehandleiding

Instructions de montage

Istruzioni di montaggio

Poresta® BFR Universalrinnenboard
 Poresta® BFR Universal Grooved Board
 Poresta® BFR universeel goot-board
 Lambris intérieur universel Poresta® BFR
 Piastra scanalata universale Poresta® BFR

Verwendung:

- Das Duschsystem Poresta® BFR kann vom Verarbeiter unter Berücksichtigung der Größe, Einbauhöhe, Geometrie und des Rinnensystems umlaufend bis auf 700 mm x 700 mm gekürzt werden.
- Für den Einbau des Duschsystems muss ein ebener, sauberer, tragfähiger, schwingungsfreier und für die Verklebung mit Profi-Flex-Schnellkleber geeigneter Untergrund vorhanden sein.
- Das Duschsystem ist generell rollstuhlbefahrbar unter Verwendung von Fliesen mit einer Mindestgröße 100 x 100 mm. Bei Einarbeitung eines Glasgewebes in das Fliesenkleberbett können auch Fliesen mit einer Mindestgröße 50 x 50 mm verwendet werden.
- Nur für den Einsatz im Innenbereich geeignet.

 Die einschlägigen Verarbeitungsrichtlinien aller beteiligten Gewerke sind zu berücksichtigen.

 **1** Beim Einbau müssen Unterbauelemente (nicht im Lieferumfang) oder ein gegossener Estrichsockel verwendet werden.

 **2** Randdämmstreifen sind bauseits zu stellen.

 **3** Für die Installation der Ablaufgarnitur ist die beiliegende Einbauanleitung des Herstellers zu beachten (nicht im Lieferumfang). Nach Installation der Ablaufgarnitur ist eine Dichtigkeitsprüfung durchzuführen.

 **4** Fliesenkleber immer beidseitig auftragen.

 **5** Hohlräume mit Fliesenkleber auffüllen.

Viega:

 **6** Bei Einbau der Ablaufgarnitur „Viega Advantix Top“ muss das Poresta® BFR Universalrinnenboard und der BFR Adapter entsprechend zugeschnitten werden. Neben dem gezeigten Einbaubeispiel sind auch andere Rohrführungen bzw. Anschlussvarianten möglich.

 **7** Eine geeignete Wärmedämm- und Schallschutzummantelung muss an der Ablaufleitung angebracht werden.

 **8** Vor Einsetzen der Ablaufrinne Hohlräume mit Fliesenkleber auffüllen. Die Ablaufrinne in aufgehäuften Fliesenkleber einsetzen und ausrichten.

 **9** Hohlräume im Übergangsbereich der Ablaufrinne zum BFR Adapter mit Fliesenkleber auffüllen und glätten.

ESS/Sanit:

 **10** Die Ablaufgarnitur muss gegebenenfalls mit geeignetem schalldämmendem Material unterlegt werden.

Dallmer:

 **11** Bei Einbau der Rinne Ceraline W muss das Poresta® BFR Universalrinnenboard und der Adapter entsprechend den Maßen der Rinne gekürzt werden.

 **12** Bei einer Estrichhöhe von 120 mm muss für den Ablauftopf eine entsprechende Aussparung im Rohfussboden erstellt werden.

Einbaubeispiel mit Poresta® BF Unterbauelement:

Aufbauhöhe/Fertigfussboden	170 mm
Poresta® BFR Universalrinnenboard	-120 mm
2 Lagen Fliesenkleber	-10 mm
Poresta® BF Unterbauelement	= 40 mm

Einbauanleitung

Mounting instruction

Montagehandleiding

Instructions de montage

Istruzioni di montaggio

Poresta® BFR Universalrinnenboard
 Poresta® BFR Universal Grooved Board
 Poresta® BFR universeel goot-board
 Lambris intérieur universel Poresta® BFR
 Piastra scanalata universale Poresta® BFR

Use:

- The Poresta® BFR shower system can be shortened by the installer up to 700 mm x 700 mm all round, considering the size, installation height, geometry and channel drain system.
- For the installation of the shower system a level, clean, solid surface free of vibrations and suited for fastening with Profi-Flex fast tile adhesive must be available.
- The shower system is generally accessible for wheel chairs when using tiles of a minimum size of 100 x 100 mm. If glass fabric is worked into the tile adhesive bed, also tiles of a minimum size of 50 x 50 mm may be used.
- Suitable only for use indoor.

 The relevant processing guidelines of all trades involved must be observed.

 **1** For the installation, either substructure elements (not included in the scope of supply) or a cast plaster floor base are required.

 **2** Edge insulation strips shall be provided by the owner.

 **3** For installation of the outlet fitting the attached manufacturer's mounting instructions are to be observed (not included in the scope of supply). After installation of the outlet fitting a leak test is to be performed.

 **4** In general, apply tile adhesive to both sides.

 **5** Fill voids with tile adhesive.

Viega:

 **6** When installing the outlet fitting „Viega Advantix Top“, it is necessary to cut the Poresta® BFR universal grooved board and BFR adapter adequately to size. Apart from the shown installation example, other pipe routings and connection variants are also possible.

 **7** The drain line is to be provided with a suitable heat and sound insulation jacketing.

 **8** Before putting the outlet channel in place, voids shall be filled with tile adhesive. Place the outlet channel in position in the piled-up tile adhesive and align it.

 **9** Fill voids in the transition area of the outlet channel to the BFR adapter with tile adhesive and smooth them up.

ESS/Sanit:

 **10** If necessary, the outlet fitting has to be underlaid with suitable sound insulation material.

Dallmer:

 **11** For installation of the Ceraline W groove it is necessary to cut the Poresta® BFR Universal Grooved Board and the adapter according to the dimensions of the groove.

 **12** At a cast plaster height of 120 mm a respective recess must be provided in the raw floor for the discharge vessel.

Example for installation with Poresta® BF substrate element:

Mounting height/finished floor level	170 mm
Poresta® BFR Universal Grooved Board	-120 mm
2 layers of tile adhesive	-10 mm
Poresta® BF substrate element	= 40 mm

Einbauanleitung

Mounting instruction

Montagehandleiding

Instructions de montage

Istruzioni di montaggio

Poresta® BFR Universalrinnenboard
 Poresta® BFR Universal Grooved Board
 Poresta® BFR universeel goot-board
 Lambris intérieur universel Poresta® BFR
 Piastra scanalata universale Poresta® BFR

Toepassing:

- Het douchesysteem Poresta® BFR kan door de monteur, rekening houdend met grootte, montagehoogte, geometrie en afvoersysteem rondom tot 700 mm x 700 mm worden ingekort.
- Voor de montage van het douchesysteem moet een vlakke, schone, draagkrachtige, trilvrije en voor verwerking van de Profi-Flex-snelplakker geschikte ondergrond aanwezig zijn.
- Het douchesysteem is in principe voor een rolstoel geschikt, als tegels met een minimale grootte van 100 x 100 mm worden toegepast. Bij verwerking van glasvezelmateriaal in de plakondergrond kunnen ook tegels van minimaal 50 x 50 mm worden gebruikt.
- Alleen geschikt voor toepassing in binnenruimte.

 Met de betreffende toepassingsrichtlijnen van alle betrokken onderdelen moet rekening worden gehouden.

 **1** Bij inbouw moeten eventueel onderbouwelementen (niet in levering inbegrepen) of een gegoten estrikondergrond worden toegepast.

 **2** Randdichtingsstroken zijn niet in de levering inbegrepen.

 **3** Voor de installatie van de afvoergarnituur moet op de montagehandleiding van de fabrikant worden gelet (niet in levering inbegrepen). Na installatie van de afvoergarnituur moet de dichtheid worden getest.

 **4** Tegelpakker altijd aan beide kanten aanbrengen.

 **5** Holle ruimtes met tegelpakker opvullen.

Viega:

 **6** Bij inbouw van de afvoergarnituur „Viega Advantix Top“ moeten het Poresta® BFR universele gootboard en de BFR adapter op maat worden gesneden. Naast het getoonde montagevoorbeeld zijn ook andere leiding- cq. aansluitingsvarianten mogelijk.

 **7** Aan de afvoerleiding moet men een geschikte warmte- en geluidsisolatie aanbrengen.

 **8** Vóór het inzetten van de afvoerleiding holle ruimtes met tegelpakker opvullen. De afvoerleiding ruim in tegelpakker zetten en uitrichten.

 **9** Holle ruimtes in de overgang van de afvoerleiding naar de BFR-adapter met tegelpakker opvullen en gladstrijken.

ESS/Sanit:

 **10** Onder de afvoergarnituur moet eventueel een geschikte geluidsisolatie worden aangebracht.

Dallmer:

 **11** Bij inbouw van de afvoer Ceraline W moeten Poresta® BFR universeel gootboard en adapter passend bij de maten van de afvoer worden ingekort.

 **12** Bij een dekvloerhoogte van 120 mm moet voor de afvoerkom een overeenkomstige uitsparing in de ruwbouwvloer worden gemaakt.

Montagevoorbeeld met Poresta® BF onderbouwelement:

Opbouwhoogte/douchebak	170 mm
Poresta® BFR universeel goot-board	-120 mm
2 lagen tegelpakker	-10 mm
Poresta® BF onderbouwelement	= 40 mm

Einbauanleitung

Mounting instruction

Montagehandleiding

Instructions de montage

Istruzioni di montaggio

Poresta® BFR Universalrinnenboard
 Poresta® BFR Universal Grooved Board
 Poresta® BFR universeel goot-board
 Lambris intérieur universel Poresta® BFR
 Piastra scanalata universale Poresta® BFR

Utilisation:

- Le système de douche Poresta® BFR peut être raccourci par l'installateur tout autour jusqu'à 700 mm x 700 mm en tenant compte des dimensions, de la hauteur de montage, de la géométrie et du système de conduit.
- Pour l'installation du système de douche, il est nécessaire de disposer d'une surface de base plane, propre, capable de porter le système, antivibratoire et appropriée à l'application de la colle rapide Profi-Flex.
- En général, le système de douche permet l'accès en fauteuil roulant à la condition de poser des carreaux d'une dimension minimale de 100 x 100 mm. Si le lit de pose des carreaux est renforcé par un tissu de fibres de verre, il est possible d'utiliser également des carreaux d'une dimension minimale de 50 x 50 mm.
- Ne se prête qu'à l'installation à l'intérieur de bâtiments.

 Les directives correspondantes de mise en oeuvre de tous les métiers participants sont à observer.

 1 Lors de l'installation, il faut utiliser des éléments de support de base (pas compris dans la fourniture) ou un socle coulé de chape.

 2 Les bandes isolantes de bord sont à fournir par le client.

 3 Pour l'installation de la robinetterie d'écoulement, il faut respecter les instructions de montage jointes du fabricant (pas comprise dans la fourniture). Après l'installation de la robinetterie d'écoulement, il faut procéder à un contrôle d'étanchéité.

 4 Appliquer la colle pour carreaux toujours sur les deux faces.

 5 Remplir les vides de colle pour carreaux

Viega:

 6 Pour l'installation de la robinetterie d'écoulement „Viega Advantix Top“, il faut couper sur mesure le lambris intérieur universel Poresta® BFR et l'élément d'adaptation BFR. En dehors de l'exemple montré, d'autres tracés des tubes ou bien d'autres variantes de raccordement sont possibles.

 7 La conduite d'écoulement doit être pourvue d'une enveloppe calorifuge et insonorisante appropriée.

 8 Avant la mise en place du conduit d'écoulement, remplir les vides de colle pour carreaux. Placer le conduit d'écoulement dans la colle accumulée et l'aligner.

 9 Dans la zone de transition du conduit d'écoulement à l'élément d'adaptation BFR, remplir les vides de colle pour carreaux et lisser.

ESS/Sanit:

 10 Le cas échéant, poser du matériel insonorisant approprié sous la robinetterie d'écoulement.

Dallmer:

 11 En cas d'installation du conduit Ceraline W, il faut raccourcir le lambris intérieur universel Poresta® BFR et l'élément d'adaptation selon les dimensions du conduit.

 12 En cas d'une hauteur de chape de 120 mm, il faut prévoir un évidement approprié dans le plancher brut pour le pot d'écoulement.

Exemple d'installation avec élément de support de base Poresta® BF:

Hauteur de montage/sol fini	170 mm
Lambris intérieur universel Poresta® BFR	- 120 mm
2 couches de colle pour carreaux	- 10 mm
Élément de support de base Poresta® BF	= 40 mm

Einbauanleitung

Mounting instruction

Montagehandleiding

Instructions de montage

Istruzioni di montaggio

Poresta® BFR Universalrinnenboard
 Poresta® BFR Universal Grooved Board
 Poresta® BFR universeel goot-board
 Lambris intérieur universel Poresta® BFR
 Piastra scanalata universale Poresta® BFR

Uso:

- Il sistema di doccia Poresta® BFR può essere accorciato dall'installatore tutt'intorno fino a 700 mm x 700 mm tenendo conto delle dimensioni, dell'altezza di montaggio, della geometria e del sistema di condotto di scolo.
- Per l'installazione del sistema doccia deve esistere un sottosuolo piano, pulito, solido, libero di vibrazioni e adatto per l'incollaggio per mezzo del collante rapido Profi-Flex.
- Il sistema doccia è generalmente accessibile con sedia a rotelle, se piastrelle di una grandezza minima di 100 x 100 mm sono usate. Ad integrazione di un tessuto di vetro nel letto d'incollaggio piastrelle anche piastrelle di una grandezza minima di 50 x 50 mm possono essere usate.
- Adatto solo per l'uso in locali chiusi.

 Si deve osservare le istruzioni corrispondenti di lavorazione di tutti i mestieri partecipanti.

 1 All'installazione, si deve utilizzare elementi di supporto di base (non compresi nella fornitura) o uno zoccolo colato di pavimento.

 2 Le fasce isolanti di bordo sono da fornire dal cliente.

 3 Per l'installazione della rubinetteria di scarico, si deve osservare le istruzioni allegate del fabbricante (non compresa nella fornitura). Dopo l'installazione della rubinetteria di scarico si deve procedere ad una prova di tenuta.

 4 Applicare l'adesivo per piastrelle sempre su entrambi i lati.

 5 Riempire le cavità con colla per piastrelle.

Viega:

 6 Per l'installazione della rubinetteria di scarico „Viega Advantix Top“ la piastra scanalata universale Poresta® BFR e l'elemento d'adattamento BFR devono essere tagliati su misura. Oltre all'esempio di montaggio mostrato ci sono altri tracciati della tubazione o altre varianti di collegamento che sono possibili.

 7 La condotta di scarico deve essere provvista di un rivestimento termoisolante ed insonorizzante appropriato.

 8 Prima di posare il cangile di scarico è necessario di riempire i vuoti di colla per piastrelle. Posare il condotto di scolo nella colla accumulata ed allinearla.

 9 Nella zona di transizione dal canale di scarico all'adattatore BFR riempire i vuoti con colla per piastrelle e lisciare.

ESS/Sanit:

 10 Eventualmente è necessario di posare materiale insonorizzante appropriato sotto la rubinetteria di scarico.

Dallmer:

 11 In caso d'installazione del condotto di scolo Ceraline W, la piastra scanalata universale Poresta® BFR e l'elemento d'adattamento devono essere raccordati secondo le dimensioni del condotto.

 12 Ad un'altezza di massetto di 120 mm si deve prevedere un incavo rispettivo nel pavimento grezzo per il recipiente di scarico.

Esempio d'installazione con elemento di supporto di base Poresta® BF:

Altezza di montaggio/ pavimento finito	170 mm
Piastra scanalata universale Poresta® BFR	-120 mm
N. 2 strati di collante per piastrelle	- 10 mm
Elemento di supporto di base Poresta® BF	= 40 mm

Einbauanleitung
Mounting instruction
Montagehandleiding
Instructions de montage
Istruzioni di montaggio

Poresta® BFR Universalrinnenboard
Poresta® BFR Universal Grooved Board
Poresta® BFR universeel goot-board
Lambris intérieur universel Poresta® BFR
Piastra scanalata universale Poresta® BFR

Empfohlenes Zubehör / Recommended accessories /
Aanbevolen toebehoren / Accessoires recommandés /
Accessori raccomandati:



illbruck Profi-Flex-Schnellkleber / Profi-Flex fast-setting
adhesive / Profi-Flex-snelplakker / Colle rapide Profi-Flex /
Collante rapido Profi-Flex

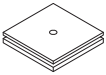

Poresta® BF Unterbauelement / Substrate element /
Onderbouwelement / Élément de support de base /
Elemento di supporto di base