

Einbauanleitung Mounting instruction Montagehandleiding Instructions de montage Istruzioni di montaggio

Poresta® Limit S KMK

Zubehör, nicht im Lieferumfang /
Accessory not included in supply /
Toebehoren, niet bij de levering inbegrepen /
Accessoires pas compris dans la fourniture /
Accessori non compresi nella consistenza di fornitura

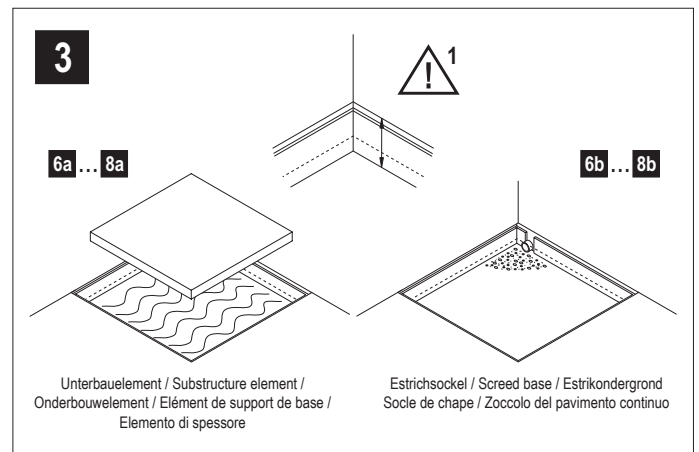
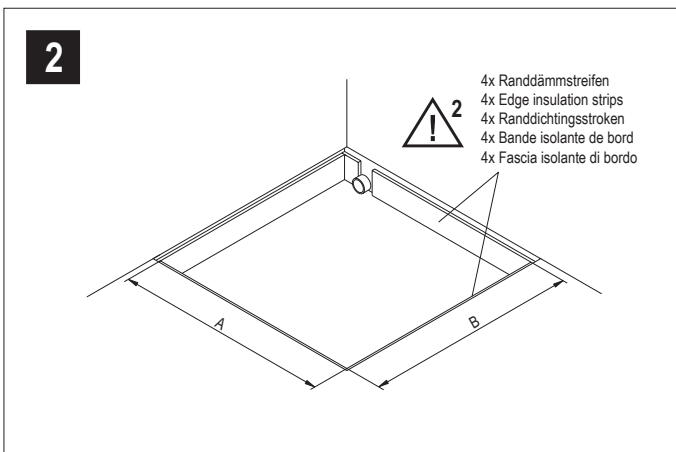
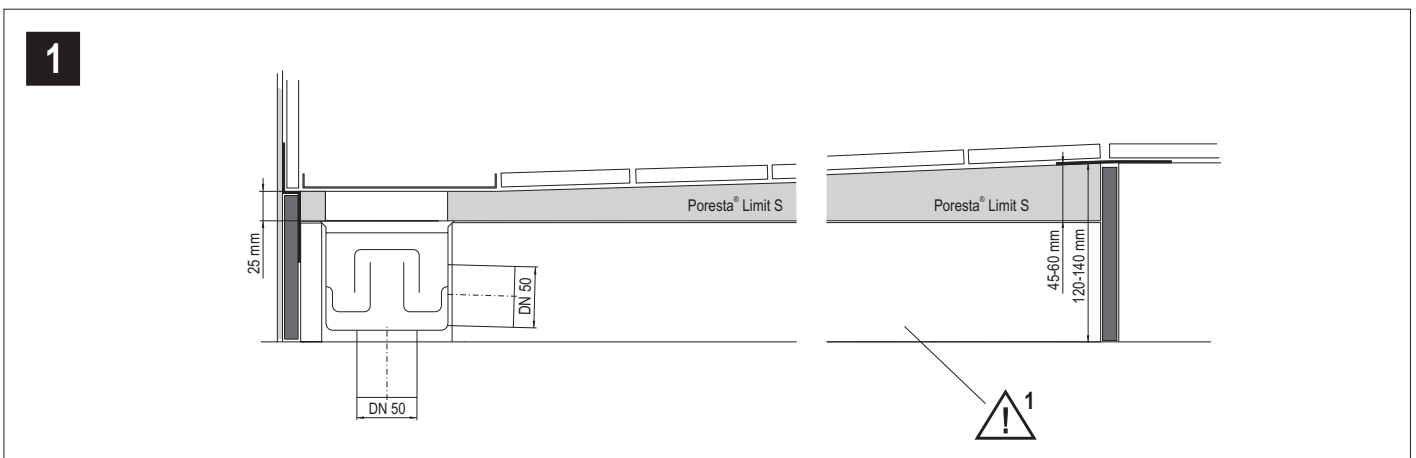
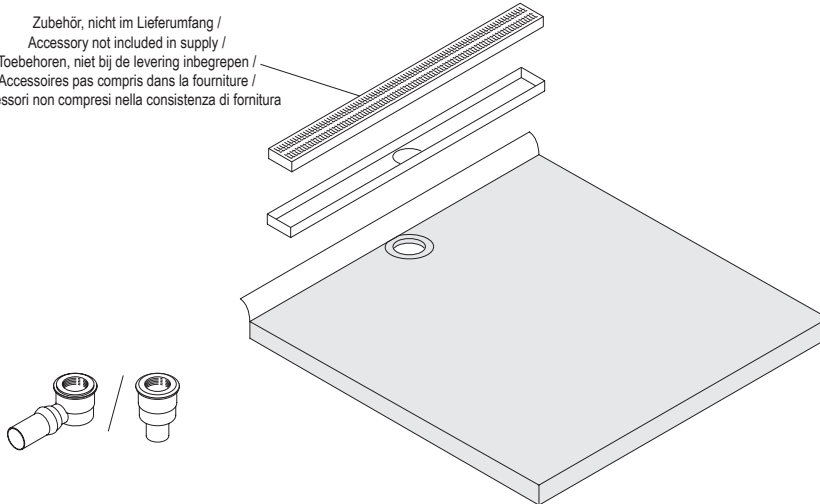

Einbauanleitung
 Mounting instruction
 Montagehandleiding
 Instructions de montage
 Istruzioni di montaggio

Poresta® Limit S KMK

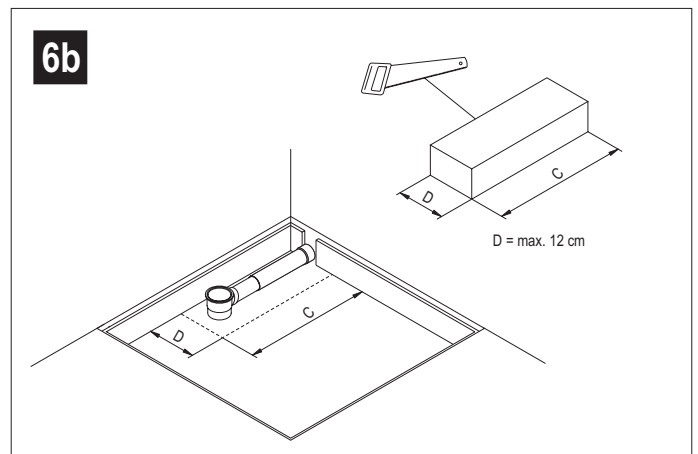
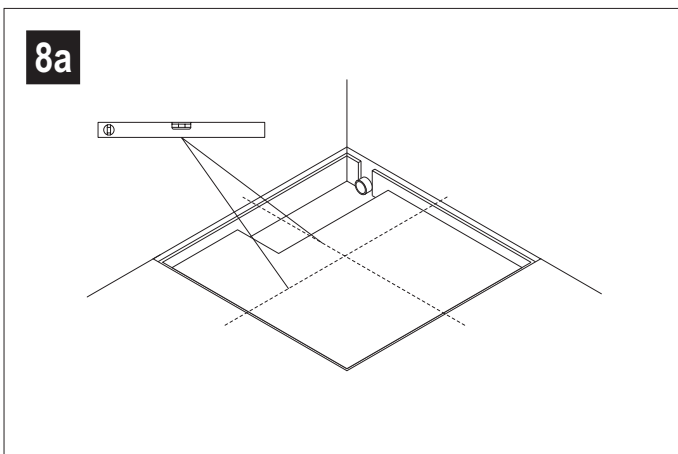
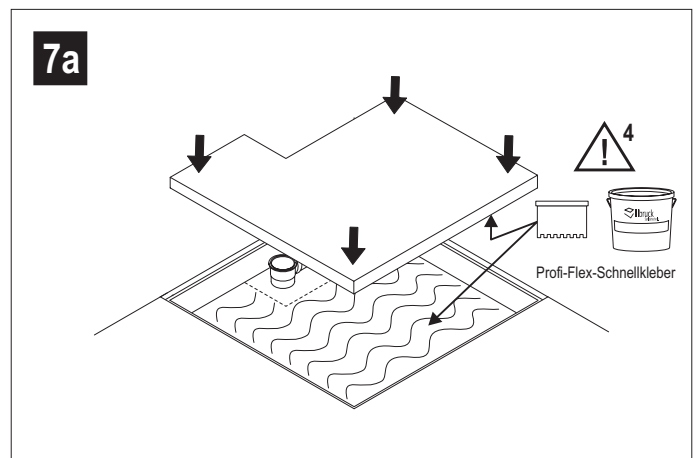
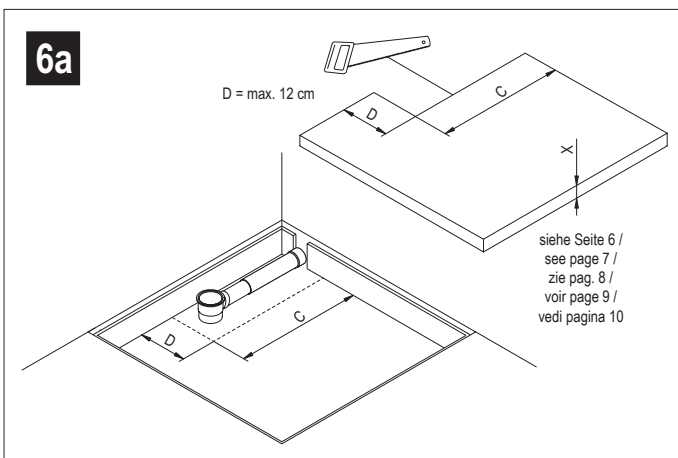
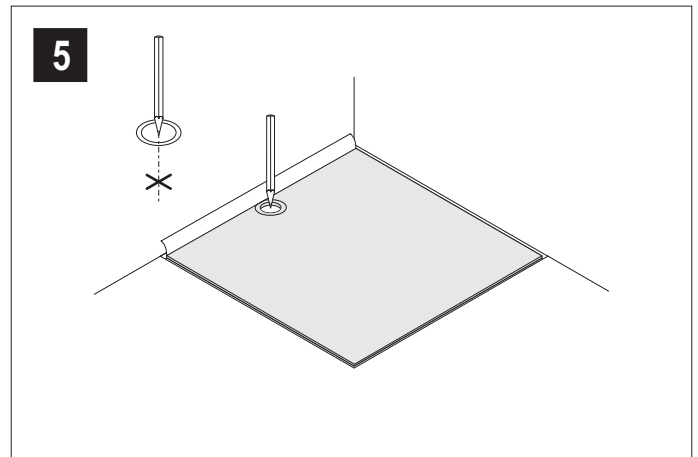
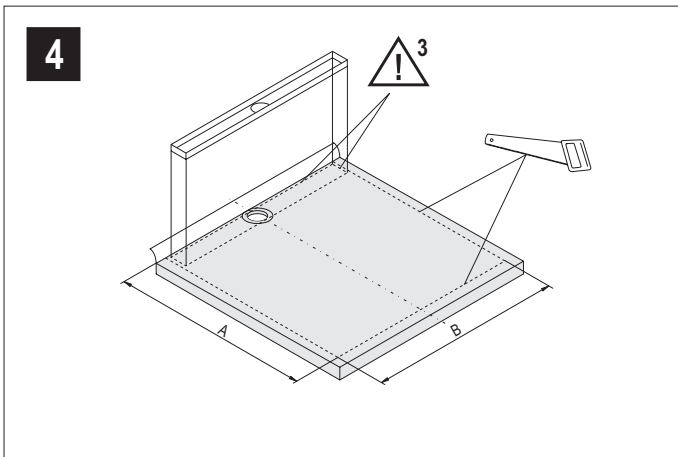

Einbauanleitung
 Mounting instruction
 Montagehandleiding
 Instructions de montage
 Istruzioni di montaggio

Poresta® Limit S KMK

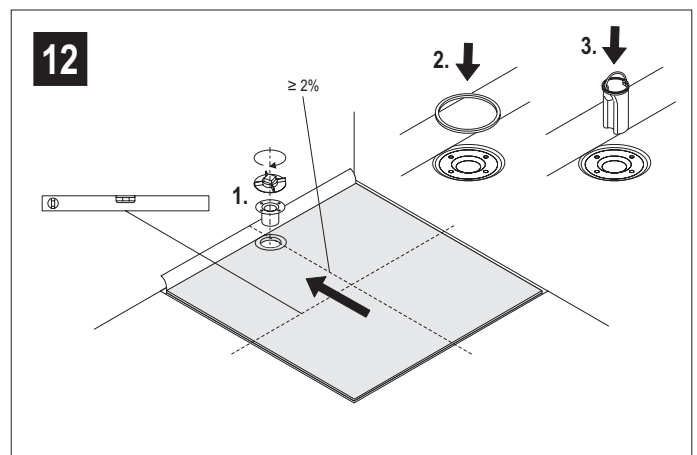
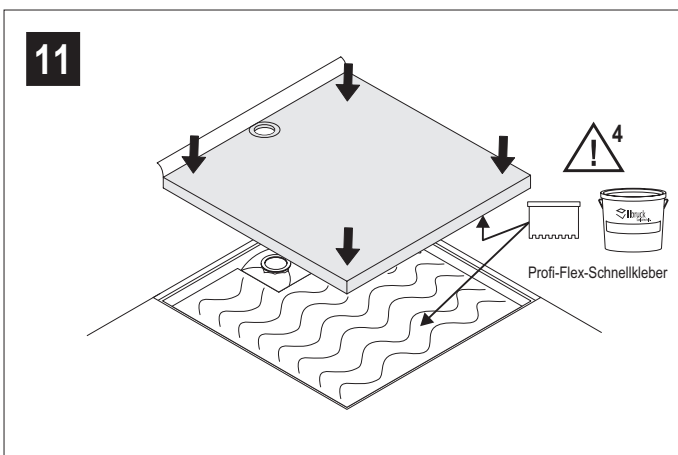
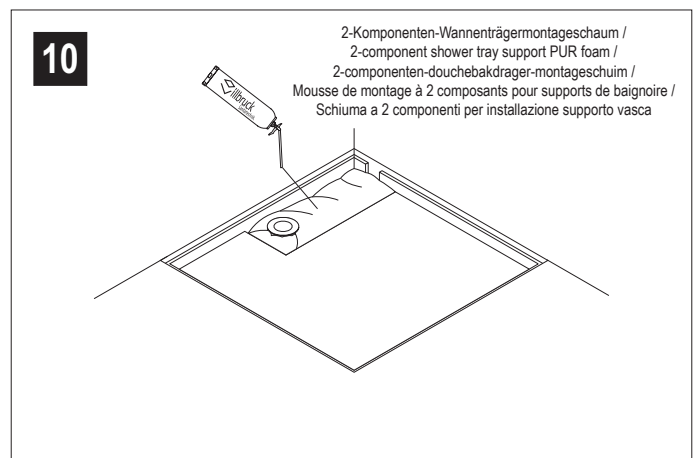
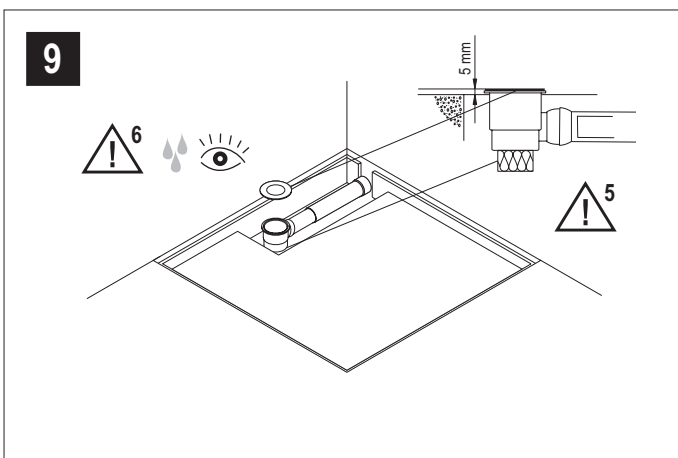
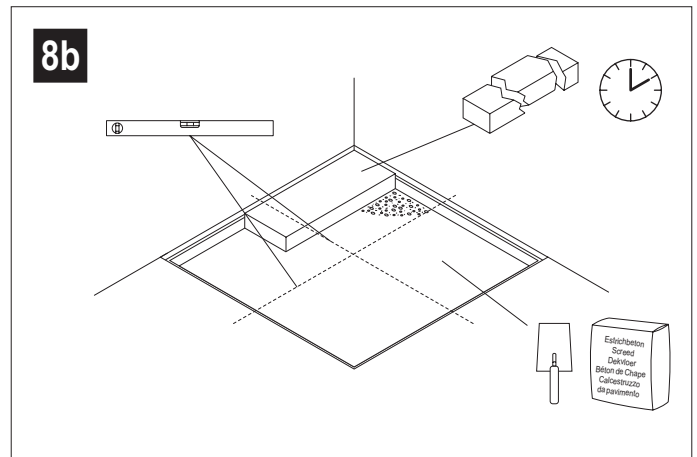
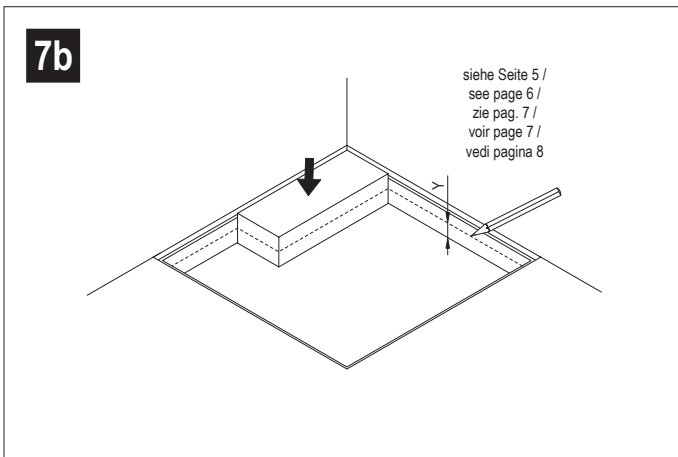

Einbauanleitung
 Mounting instruction
 Montagehandleiding
 Instructions de montage
 Istruzioni di montaggio

Poresta® Limit S KMK

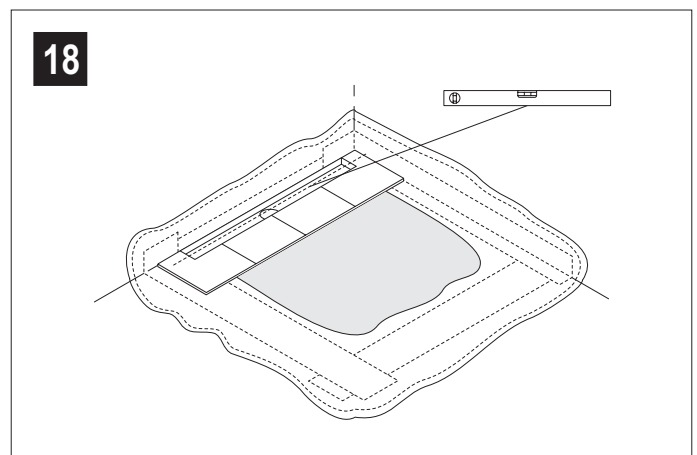
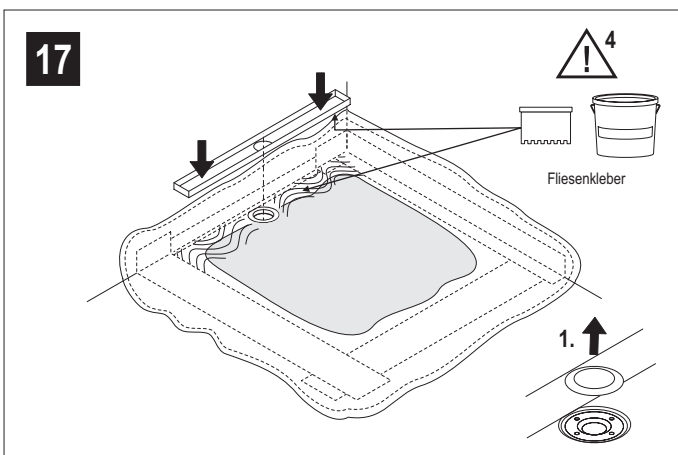
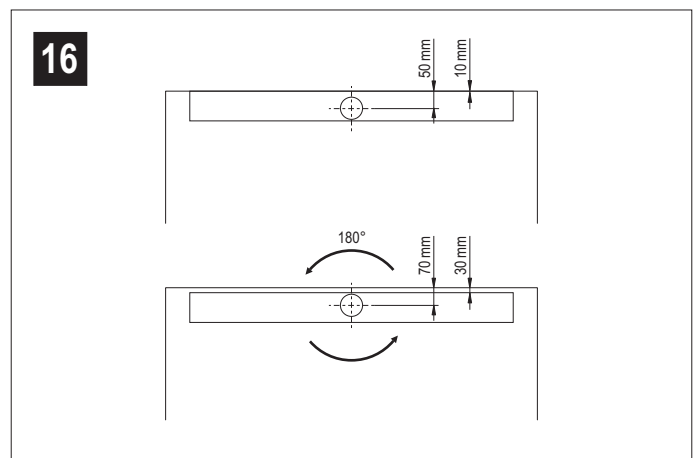
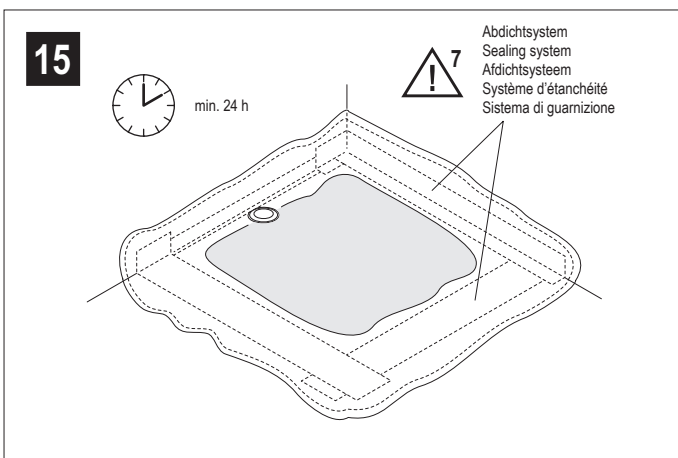
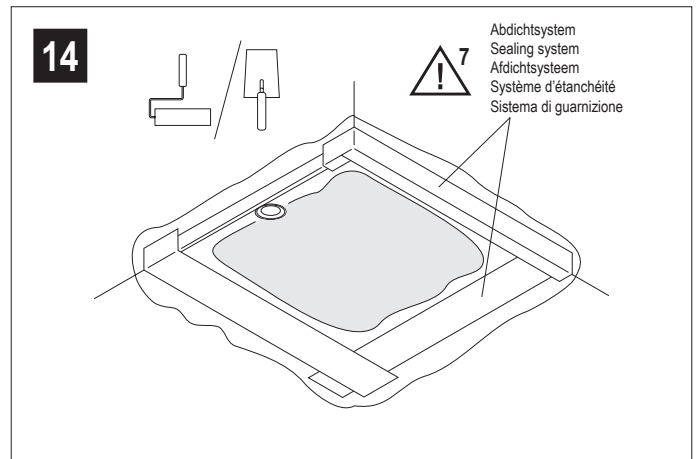
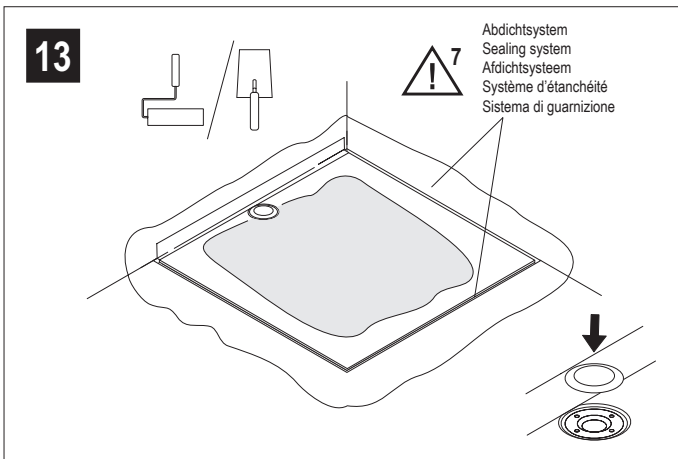

Einbauanleitung
Mounting instruction
Montagehandleiding
Instructions de montage
Istruzioni di montaggio

Poresta® Limit S KMK

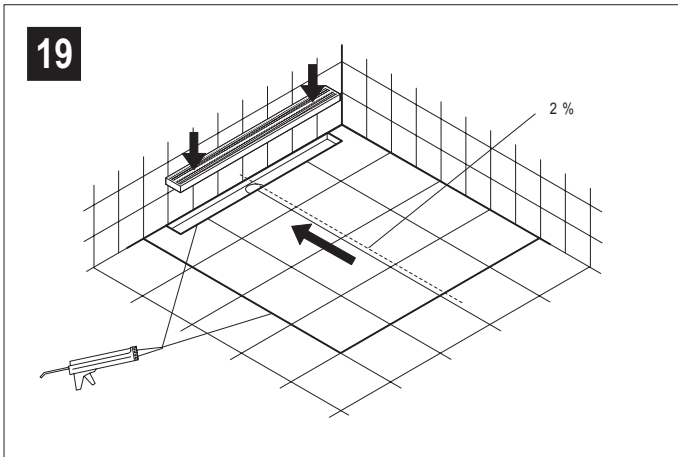

Einbauanleitung

Mounting instruction

Montagehandleiding

Instructions de montage

Istruzioni di montaggio

Poresta® Limit S KMK

Verwendung:

- Das Duschsystem Poresta® Limit S kann vom Verarbeiter unter Berücksichtigung der Größe, Einbauhöhe und der Geometrie des Duschsystems/Edelstahlrostsystems seitlich bis zu 50 mm und an der Längsseite variabel gekürzt werden.
- Für den Einbau des Duschsystems muss ein ebener, sauberer, tragfähiger, schwingungsfreier und für die Verklebung mit Profi-Flex-Schnellkleber geeigneter Untergrund vorhanden sein.
- Die dezentrierte Ablaufposition in der Rostaufnahme ermöglicht durch den entstehenden unterschiedlichen Abstand von der Wand die Verwendung von Standardfliesen oder Naturstein als Wandbelag (siehe Abbildung 16).
- Das Duschsystem ist generell rollstuhlbefahrbar unter Verwendung von Fliesen mit einer Mindestgröße 100 x 100 mm. Bei Einarbeitung eines Glasgewebes in das Fliesenkleberbett können auch Fliesen mit einer Mindestgröße 50 x 50 mm verwendet werden.
- Nur für den Einsatz im Innenbereich geeignet.

Einbaubeispiel mit Poresta® BF Unterbauelement (X):

Aufbauhöhe/Fertigfussboden	140 mm
Poresta® Limit S	- 60 mm
2 Lagen Fliesenkleber	-10 mm
<hr/>	
Poresta® BF Unterbauelement (X)	= 70 mm

Einbaubeispiel mit Estrichsockel (Y):

Aufbauhöhe/Fertigfussboden	140 mm
Poresta® Limit S	- 60 mm
1 Lage Fliesenkleber	- 5 mm
<hr/>	
Estrichsockel (Y)	= 75 mm

 Die einschlägigen Verarbeitungsrichtlinien aller beteiligten Gewerke sind zu berücksichtigen.

 ¹ Beim Einbau müssen Unterbauelemente (nicht im Lieferumfang, siehe Abb. 6a bis 8a) oder ein gegossener Estrichsockel (siehe Abb. 6b bis 8b) verwendet werden. Die Höhe des Unterbauelementes/Estrichsockels ist anhand des Höhenunterschiedes zwischen Rohfußboden und Raumestrich zu wählen (siehe auch Einbaubeispiele).

 ² Randdämmstreifen sind bauseits zu stellen.

 ³ Den Abstand zur Wand unter Berücksichtigung des geplanten Wandaufbaus wählen.

 ⁴ Fliesenkleber beidseitig auftragen.

 ⁵ Die Ablaufgarnitur muss gegebenenfalls mit geeignetem schalldämmenden Material unterlegt werden.

 ⁶ Nach Installation der Ablaufgarnitur ist eine Dichtigkeitsprüfung durchzuführen.

 ⁷ Die Verarbeitungshinweise des Abdichtsystems sind zu beachten.

Einbauanleitung

Mounting instruction

Montagehandleiding

Instructions de montage

Istruzioni di montaggio

Poresta® Limit S KMK

Use:

- The Poresta® Limit S shower system can be shortened by the installer by up to 50 mm at the sides and variably at the long side, taking into account the size, installation height and geometry of the shower system/stainless steel grate system.
- For the installation of the shower system a level, clean, solid surface free of vibrations and suited for fastening with Profi-Flex fast tile adhesive must be available.
- Due to the different distances from the wall, the decentred drain position in the grate fitting frame allows the use of standard tiles or natural stone as wall covering (see Fig. 16).
- The shower system is generally accessible for wheel chairs when using tiles of a minimum size of 100 x 100 mm. If glass fabric is worked into the tile adhesive bed, also tiles of a minimum size of 50 x 50 mm may be used.
- Suitable only for use indoor.

Example for installation with Poresta® BF substructure element (X):

Mounting height/finished floor level	140 mm
Poresta® Limit S	- 60 mm
2 layers of tile adhesive	-10 mm
Poresta® BF substructure element (X)	= 70 mm

Installation example with screed base (Y):

Mounting height/finished floor level	140 mm
Poresta® Limit S	- 60 mm
1 layer of tile adhesive	- 5 mm
Screed base (Y)	= 75 mm

 The relevant processing guidelines of all trades must be observed.

 ¹ For installation substructure elements (not included in supply, see figs. 6a to 8a) or a cast screed base (see figs. 6b to 8b) are to be used. The height of the substructure element/screed base is to be selected according to the difference in height between the raw floor and the room flooring (see also installation examples).

 ² Edge insulation strips are to be provided locally.

 ³ Select the distance from the wall in consideration of the planned wall set-up.

 ⁴ Apply tile adhesive to both sides

 ⁵ The drain fitting must possibly be lined with suitable sound absorbing material.

 ⁶ After the installation of the drain fitting, a leakage test must be carried out.

 ⁷ The processing instructions of the sealing system are to be observed.

Einbauanleitung

Mounting instruction

Montagehandleiding

Instructions de montage

Istruzioni di montaggio

Poresta® Limit S KMK

Toepassing:

- Het douchesysteem Poresta® Limit S kan door de installateur afhankelijk van maten, inbouwhoogte en geometrie van het douche-systeem/fijnstaal-gridsysteem aan de zijkanten tot 50 mm en aan de lange kant variabel worden verkort.
- Voor de montage van het douchesysteem moet een vlakke, schone, draagkrachtige, trilvrije en voor verwerking van de Profi-Flex-snelplakker geschikte ondergrond aanwezig zijn.
- De decentrale afvoer in de gridgarnituur maakt door de variabele afstand tot de wand de toepassing van standaardtegels of natuursteen op de wand mogelijk. (zie afbeelding 16).
- Het douchesysteem is in principe voor een rolstoel geschikt, als tegels met een minimale grootte van 100 x 100 mm worden toegepast. Bij verwerking van glasvezelmateriaal in de plakondergrond kunnen ook tegels van minimaal 50 x 50 mm worden gebruikt.
- Alleen geschikt voor toepassing in binnenruimte.

 Met de betreffende verwerkingsrichtlijnen van alle betrokken onderdelen moet rekening worden gehouden.

 ¹ Bij inbouwen moeten de onderbouwelementen (niet in de levering inbegrepen, zie afb. 6a t/m 8a) of een gegoten estrikondergrond (zie afb. 6b t/m 8b) worden toegepast. De hoogte van het onderbouwelement/estrikondergrond moet aan de hand van het hoogteverschil tussen onafgewerkte vloer en kamerestrik worden gekozen (zie ook installatievoorbeelden).

 ² Randdichtingsstroken zijn niet in de levering inbegrepen.

 ³ De afstand tot de wand afhankelijk van de geplande wandopbouw kiezen.

 ⁴ Tegelplakker aan beide kanten aanbrengen.

 ⁵ De afvoergarnituur moet eventueel met geschikt geluiddempend materiaal worden geïsoleerd.

 ⁶ Na de installatie van de waterafvoer moet een dichtheidscontrole worden uitgevoerd.

 ⁷ De verwerkingsaanwijzingen van het afdichtsysteem moeten worden opgevolgd.

Montagevoorbeeld met Poresta® BF onderbouwelement (X):

Opbouwhoogte/afgewerkte vloer	140 mm
Poresta® Limit S	- 60 mm
2 lagen tegelplakker	-10 mm
Poresta® BF onderbouwelement (X)	= 70 mm

Montagevoorbeeld met estrikondergrond (Y):

Opbouwhoogte/afgewerkte vloer	140 mm
Poresta® Limit S	- 60 mm
1 laag tegelplakker	- 5 mm
Estrikondergrond (Y)	= 75 mm

Einbauanleitung

Mounting instruction

Montagehandleiding

Instructions de montage

Istruzioni di montaggio

Poresta® Limit S KMK

Utilisation:

- Le système de douche Poresta® Limit S peut être raccourci par l'installateur latéralement de jusqu'à 50 mm et variablement sur le grand côté tout en tenant compte des dimensions, de la hauteur de montage et de la géométrie du système de douche / du système de grille en acier fin.
- Pour l'installation du système de douche, il est nécessaire de disposer d'une surface de base plane, propre, capable de porter le système, antivibratoire et appropriée à l'application de la colle rapide Profi-Flex.
- Grâce à la position décentrée de l'écoulement dans le logement de la grille, l'écart par rapport au mur est différent, ce qui permet d'utiliser pour le revêtement du mur selon le cas des carreaux standard ou de la pierre naturelle (voir fig. 16).
- En général, le système de douche permet l'accès en fauteuil roulant à la condition de poser des carreaux d'une dimension minimale de 100 x 100 mm. Si le lit de pose des carreaux est renforcé par un tissu de fibres de verre, il est possible d'utiliser également des carreaux d'une dimension minimale de 50 x 50 mm.
- Ne se prête qu'à l'installation à l'intérieur de bâtiments.

 Les directives correspondantes de mise en oeuvre de tous les métiers participants sont à observer.

 ¹ Pour l'installation, il faut utiliser des éléments de support de base (pas compris dans la fourniture, voir fig. 6a - 8a) ou un socle de chape coulée (voir fig. 6b - 8b). Choisir la hauteur de l'élément de support de base/du socle de chape selon la différence de hauteur entre le sol brut et la chape de la salle (voir exemples d'installation).

 ² Les bandes isolantes de bord sont à prévoir par le client.

 ³ Choisir la distance au mur en tenant compte de la construction murale prévue.

 ⁴ Appliquer de colle pour carreaux sur les deux faces.

 ⁵ Le cas échéant, de la matière insonorisante doit être posée sous la garniture d'écoulement.

 ⁶ Après installation de la garniture d'écoulement, procéder à un essai d'étanchéité.

 ⁷ Respecter les instructions de mise en oeuvre du système d'étanchéité.

Exemple d'installation avec élément de support de base Poresta® BF (X):

Hauteur de montage/sol fini	140 mm
Poresta® Limit S	- 60 mm
2 couches de colle pour carreaux	-10 mm
<hr/>	
Élément de support de base Poresta® BF(X)	= 70 mm

Exemple d'installation avec socle de chape (Y):

Hauteur de montage/sol fini	140 mm
Poresta® Limit S	- 60 mm
1 couche de colle pour carreaux	- 5 mm
<hr/>	
Socle de chape (Y)	= 75 mm

Einbauanleitung

Mounting instruction

Montagehandleiding

Instructions de montage

Istruzioni di montaggio

Poresta® Limit S KMK

Uso:

- Il sistema doccia Poresta® Limit S può essere accorciato dall'installatore in considerazione della grandezza, dell'altezza d'installazione e della geometria del sistema doccia lateralmente fino a 50 mm e sul lato longitudinale in modo variabile.
- Per l'installazione del sistema doccia deve esistere un sottosuolo piano, pulito, solido, libero di vibrazioni e adatto per l'incollaggio per mezzo del collante rapido Profi-Flex.
- La posizione di scarico decentrale nel supporto della griglia rende possibile l'uso di piastrelle standard o pietra naturale come rivestimento murale a causa della distanza differente dal muro (vedi fig. 16).
- Il sistema doccia è generalmente accessibile con sedia a rotelle, se piastrelle di una grandezza minima di 100 x 100 mm sono usate. Ad integrazione di un tessuto di vetro nel letto d'incollaggio piastrelle anche piastrelle di una grandezza minima di 50 x 50 mm possono essere usate.
- Adatto solo per l'uso interno.

Esempio d'installazione con elemento di spessore (X) Poresta® BF:

Altezza di montaggio/ pavimento finito	140 mm
Poresta® Limit S	- 60 mm
N. 2 strati di collante per piastrelle	-10 mm
Elemento di spessore (X) Poresta® BF	= 70 mm

Esempio d'installazione con zoccolo di pavimento (Y):

Altezza di montaggio/ pavimento finito	140 mm
Poresta® Limit S	- 60 mm
N. 1 strato di collante per piastrelle	- 5 mm
Zoccolo di pavimento (Y)	= 75 mm

 Si deve osservare le istruzioni di lavorazione di tutti i mestieri partecipanti.

 ¹ Per l'installazione elementi di spessore (non compresi nella consistenza di fornitura, vedi anche fig. 6a – 8a) o uno zoccolo di pavimento continuo (vedi fig. 6b – 8b) devono essere usati. L'altezza dell'elemento di spessore/dello zoccolo di pavimento deve essere scelta secondo la differenza d'altezza tra fondo grezzo e pavimento camera (vedi anche esempi d'installazione).

 ² Fasce isolanti di bordo devono essere messe a disposizione localmente.

 ³ Scegliere la distanza dal muro in considerazione della struttura di parete stabilita.

 ⁴ Applicare l'adesivo per piastrelle su entrambi i lati.

 ⁵ L'elemento di scarico deve essere rivestito in caso con materiale isolante addetto.

 ⁶ Dopo l'installazione dell'elemento di scarico, si deve procedere ad una prova d'ermeticità.

 ⁷ Le istruzioni di lavorazione del sistema di guarnizione devono essere osservate.

Einbauanleitung Mounting instruction Montagehandleiding Instructions de montage Istruzioni di montaggio

Poresta® Limit S KMK

Empfohlenes Zubehör / Recommended accessories /
Aanbevolen toebehoren / Accessoires recommandés /
Accessori raccomandati:



illbruck Profi-Flex-Schnellkleber / Profi-Flex fast-setting
adhesive / Profi-Flex-snelplakker / Colle rapide Profi-Flex /
Collante rapido Profi-Flex



illbruck Abdichtungssystem / Sealing system / Afdichtingsysteem /
Système d'étanchéité / Sistema di guarnizione

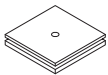

Poresta® BF Unterbauelement / Substrate element /
Onderbouwelement / Élément de support de base /
Elemento di supporto di base



Poresta® BF Dichtband / Sealing tape / Afdichtingsband /
Bande isolante / Fascia isolante



Poresta® BF Dichtband-Innenecke / Sealing tape interior
corner / Afdichtingsband-binnenliggende hoek / Bande
isolante pour coin intérieur / Fascia isolante per angolo
interno

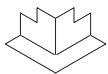

Poresta® BF Dichtband-Außenecke / Sealing tape
exterior corner / Afdichtingsband-buitenliggende hoek /
Bande isolante pour coin extérieur / Fascia isolante per
angolo esterno



Geeigneter Fliesenkleber / Suitable tile adhesive /
Geschikte tegelplakker / Colle appropriée pour carreaux /
Collante per piastrelle adatto



Silikon / Silicone / Siliconen / Silicone / Silicone



2-Komponenten-Wannenträgermontageschaum /
2-component shower tray support PUR foam /
2-componenten-douchebakdrager-montageschuim /
Mousse de montage à 2 composants pour supports de
baignoire / Schiuma a 2 componenti per installazione
supporto vasca



Weitere Rostdesigns / Further drain cover designs /
Verdere afvoergarnituur-designs / Autres types de grille
d'écoulement / Ulteriori esecuzioni di griglia di copertura