

Einbauanleitung

Poresta® Schallschutzset SIA 181 für Stahlduschwannen

Mounting instruction

Poresta® Sound Proofing Set SIA 181 for Steel Shower Trays

Montagehandleiding

Poresta® Geluidsisolatieset SIA 181 voor stalen douchekeup

Instructions de montage

Matériel insonorisant Poresta® SIA 181 pour cuves à douche en acier

Istruzioni di montaggio

Materiale insonorizzante Poresta® SIA 181 per piatti doccia in acciaio

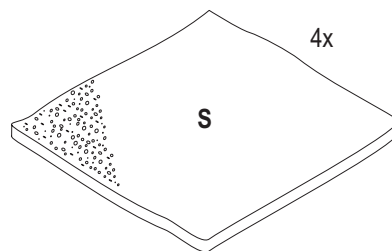

Poresta® Schalldämpfungsmatte /
Sound absorbing mat /
Geluidsisolatiemat /
Matelas insonorisant /
Stuoia insonorizzante



Poresta® Schallentkopplungsstreifen /
Antiresonant strip /
Geluidsisolatiestroken /
Bande d'isolation acoustique /
Fascia d'isolamento acustico



Poresta® Dämm- und Schutzband /
Insulating and protective strip /
Wandisolatieband /
Bande d'insonorisation et de protection /
Fascia d'insonorizzazione e di protezione



Befestigungsstifte /
Fastening pins /
Bevestigingspennen /
Chevilles de fixation /
Caviglie di fissaggio

Notes and further information see page 5 /
Referenties en meer informatie, zie pagina 5 /
Renseignnement et informations complémentaires, voir page 6 /
Riferimenti e ulteriori informazioni, vedere pagina 6

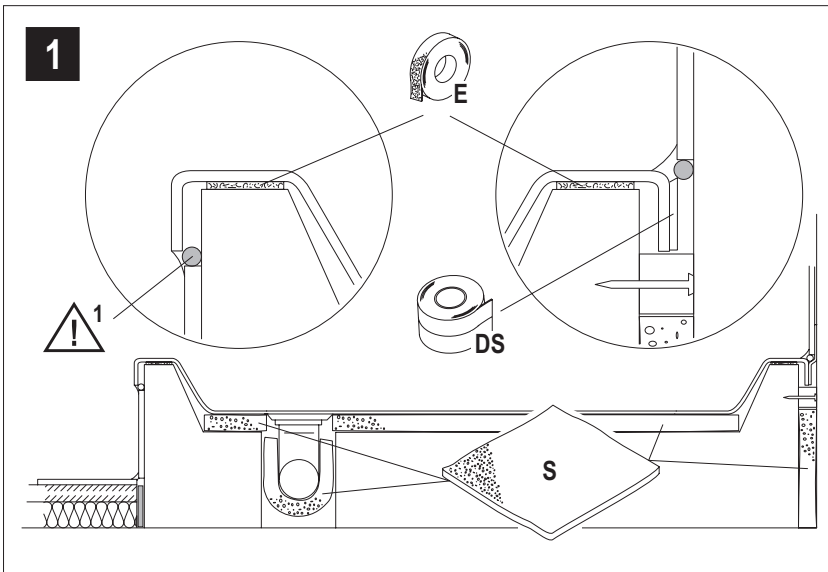

⚠ Die einschlägigen Verarbeitungsrichtlinien aller beteiligten Gewerke sind zu berücksichtigen.

⚠ Für die Verwendung des Schallschutzsets sind Schallprüfberichte nach SIA 181 verfügbar. Zur Einhaltung der gemessenen Installationschallpegel müssen die aufgeführten Poresta® Produkte fachgerecht verwendet werden.

⚠ 1 Vor Verfugen der Duschwanne mit Silikon ein weiches Hinterfüllmaterial einzubringen.

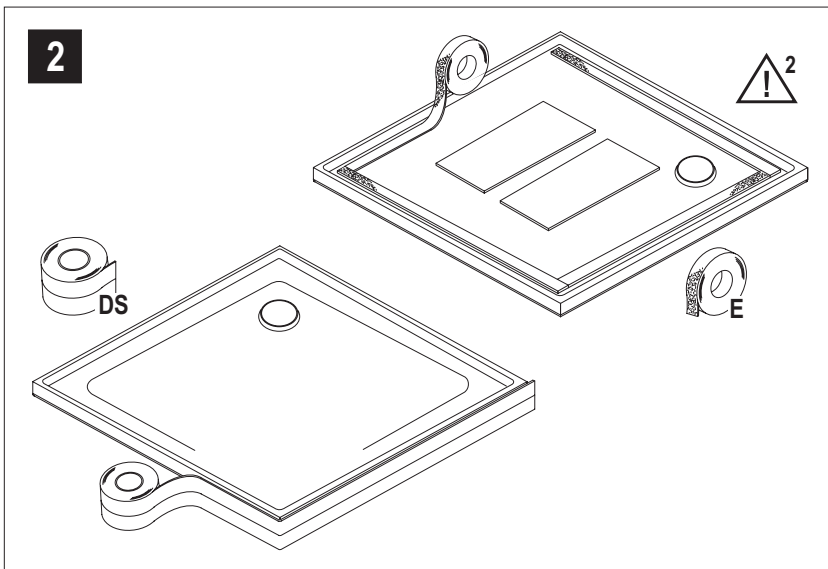

⚠ 2 Die Schallentkopplungsstreifen (E) sind auf der Rückseite der Duschwanne anzubringen.

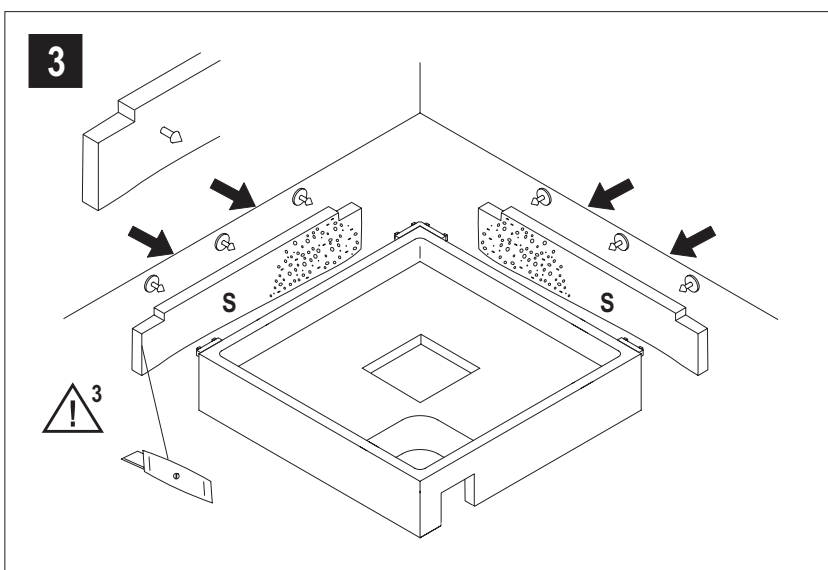

⚠ 3 Die Schalldämpfungsmatte zuschneiden und einlagig an den hinteren, äußeren Seitenwänden des Wannenträgers 2 cm unterhalb des Randes feststecken. Die Befestigungsschrauben erst durch die Schalldämpfungsmatte stecken und danach am Duschwannenträger feststecken.

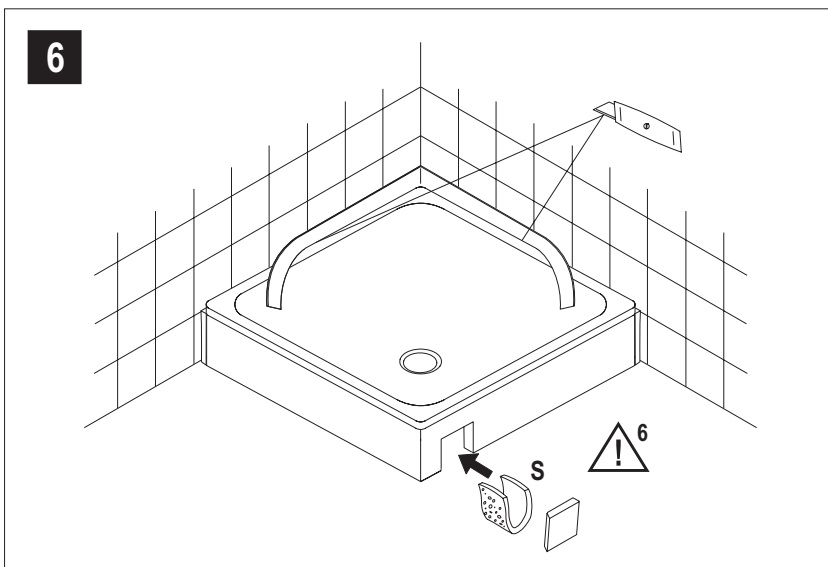
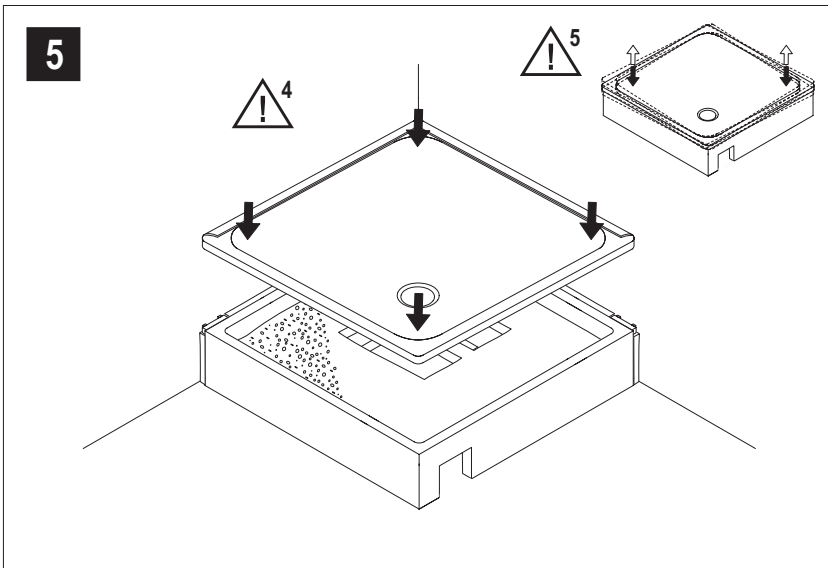
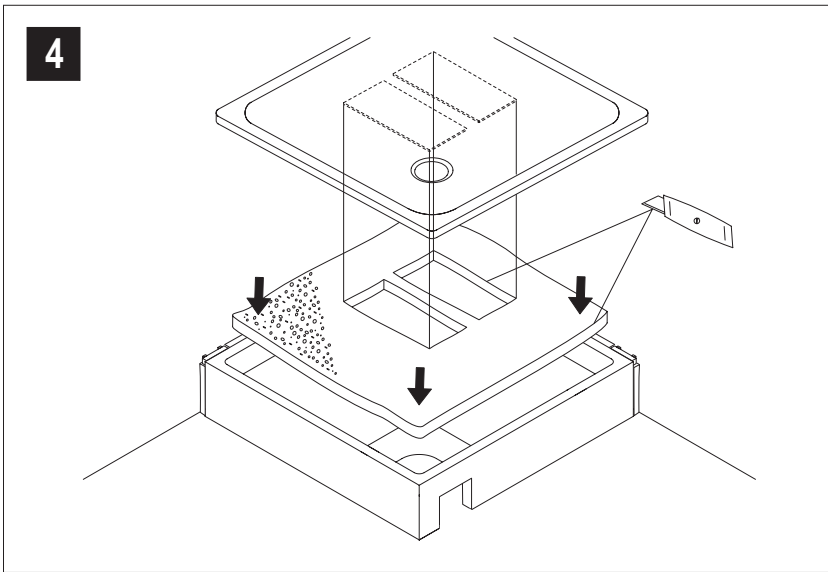







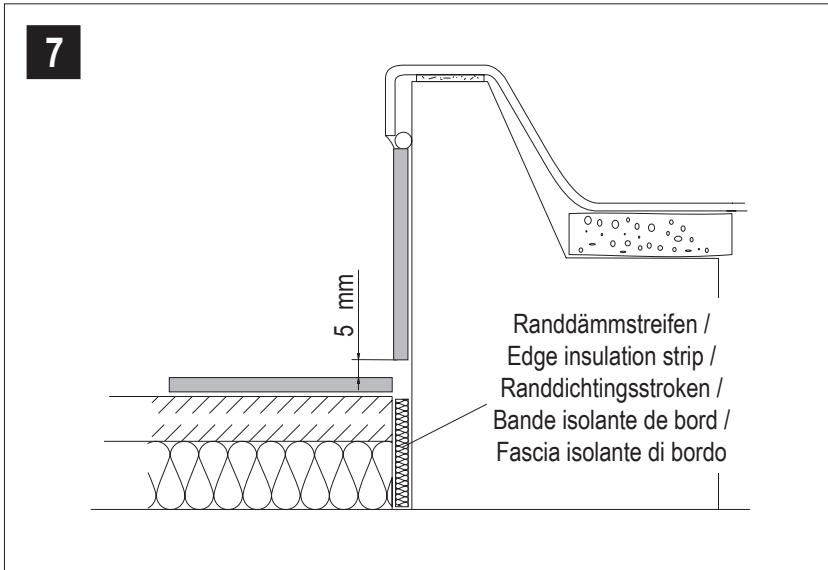

























! 4 Der weitere Einbau des Poresta® Duschwannenträgers, der Ablaufgarnitur und der Duschwanne erfolgt gemäß der jeweiligen Einbauanleitung.

! 5 Die Duschwanne darf nicht im Poresta® Duschwannenträger kippen, gegebenenfalls die Schalldämpfungsmatte in den betroffenen Bereichen kleinflächig entfernen. Bei Duschwannenträgern mit Verstellböden sind diese aus der Schalldämpfungsmatte freizuschneiden.

! 6 Vor Verschließen der Revisionsöffnung Reststücke der Schalldämpfungsmatte in vorhandene Hohlräume einbringen.



-
-  The relevant processing guidelines of all trades involved must be observed.
-  Sound test certificates according to SIA 181 are available for the use of the sound proofing set. The Poresta® products must be used expertly to observe the measured installation sound levels.
-  1 Before pointing the joints of the shower tray with silicone, a soft backfilling material is to be used.
-  2 The antiresonant strips (E) have to be fixed at the back of the shower tray.
-  3 Cut to size sound absorbing mat and attach it at one layer to the rear side walls of the tray carrier 2 cm beneath the edge. The fastening pins are at first put through the sound absorbing mat and then stuck into the shower tray carrier.
-  4 The installation of the Poresta® shower tray carrier, the outlet fitting and the shower tray is effected according to the respective mounting instructions.
-  5 The shower tray may not wobble in the Poresta® shower tray supporting frame, remove small sections of the sound absorbing mat in the relevant areas, if necessary. For shower tray supporting frames with adjustable bottoms the same are to be cut off the sound absorbing mat.
-  6 Place offcuts of the sound absorbing mat in the existing hollows before closing the inspection opening.
-  Met de betreffende verwerkingsrichtlijnen van alle betrokken leveranciers moet rekening worden gehouden.
-  Voor de toepassing van de isolatieset in verbinding met Poresta® drempelloze douchesystemen zijn certificaten volgens SIA 181 beschikbaar. Om de mogelijke grenswaarden te bereiken, moeten de genoemde Poresta® producten vakkundig worden verwerkt.
-  1 Voor het afvoegen van de douchekuip met siliconen moet zacht opvulmateriaal worden aangebracht.
-  2 De geluidsisolatiestroken (E) aan de achterkant van de douchebak aanbrengen
-  3 De geluidsisolatiemat in één laag aan de binnenkant van de zijwanden van de douchekuipdrager 2 cm onder de rand vaststeken. De bevestigingspennen eerst door de isolatiemat steken en daarna aan de badkuipdrager vaststeken. In de bodemsector kunnen de isolatiematten elkaar overlappen.
-  4 De inbouw van de Poresta® douchekuipdrager, de afvoergarnituur en de douchekuip gebeurt volgens de desbetreffende inbouwhandleiding.
-  5 De douchekuip mag in de Poresta® badkuipdrager niet slingeren, evt. geluidsdempingsmat op betroffen plaatsen gedeeltelijk verwijderen. Bij douchekuipdragers met verstelbare bodems moeten deze uit de geluidsisolatiemat gesneden worden.
-  6 Voor het sluiten van de revisie-opening reststukken van de geluidsisolatiemat in aanwezige holle ruimtes stoppen.

-  Les directives correspondantes de mise en oeuvre de tous les métiers participants sont à observer.
-  Pour l'utilisation du matériel d'insonorisation, des certificats de contrôle du bruit selon SIA 181 sont disponibles. Pour obtenir les niveaux sonores d'installation mesurés, il est nécessaire d'effectuer la mise en oeuvre des produits Poresta® indiqués conformément aux règles de l'art.
-  1 Avant de procéder au jointoiment au moyen de silicone de la cuve à douche, il faut appliquer de la matière de remplissage molle.
-  2 Les bandes d'isolation acoustique (E) sont à disposer côté arrière de la cuve à douche.
-  3 Couper sur mesure le matelas insonorisant, le placer en une couche et le fixer aux parois latérales postérieures du support de la cuve, à 2 cm au-dessous du bord. Pousser d'abord les chevilles de fixation à travers le matelas et puis les fixer au support de la cuve à douche.
-  4 L'installation du support de cuve à douche Poresta®, de la robinetterie d'écoulement et de la cuve à douche doit s'effectuer conformément aux instructions de montage respectives.
-  5 La cuve à douche doit avoir une position tout à fait stable sur le support de cuve à douche Poresta®, le cas échéant, enlever le matelas insonorisant sur une surface réduite dans les zones concernées. En cas de supports de cuve à douche avec fond réglable, il faut couper une ouverture correspondante pour le fond dans le matelas insonorisant.
-  6 Avant de fermer l'ouverture d'inspection, placer les bouts restants du matelas insonorisant dans les espaces vides existants.
-  Si deve osservare le istruzioni corrispondenti di lavorazione di tutti i mestieri partecipanti.
-  Per l'utilizzazione del materiale d'insonorizzazione sono disponibili certificati di controllo del rumore secondo SIA 181. Per ottenere i livelli sonori d'installazione misurati è necessario di far attenzione alla messa in opera a regola d'arte dei prodotti Poresta® indicati.
-  1 Prima di turare con silicone le commessure del piatto doccia è necessario di applicare materiale morbido di riempimento.
-  2 Le fasce d'isolamento acustico (E) sono da posare lato posteriore del piatto doccia.
-  3 La stuoia insonorizzante deve essere tagliata su misura e poi essere posata in uno strato e fissato sulle pareti laterali posteriori del supporto del piatto doccia, a 2 cm al di sotto del bordo. Le caviglie di fissaggio devono essere conficcate prima attraverso la stuoia e poi essere fissate sul supporto del piatto doccia.
-  4 L'installazione del supporto del piatto doccia Poresta®, della robinetteria di scarico e del piatto doccia è da eseguire in conformità alle istruzioni di montaggio rispettive.
-  5 Il piatto di doccia non deve dondolare nel supporto del piatto di doccia Poresta®, rimuovere eventualmente la stuoia insonorizzante da una parte ridotta della superficie nelle zone interessate. In caso di supporti del piatto di doccia con fondi regolabili gli stessi devono essere tagliati dalla stuoia insonorizzante.
-  6 Mettere i resti della stuoia insonorizzante nelle cavità esistenti prima di chiudere l'apertura di ispezione.