

Einbauanleitung

Poresta® Schallschutzset DIN 4109 für Stahlbadewannen

Mounting instruction

Poresta® Sound Proofing Set DIN 4109 for Steel Bath Tubs

Montagehandleiding

Poresta® Geluidsisolatieset DIN 4109 voor stalen badkuip

Instructions de montage

Matériel insonorisant Poresta® DIN 4109 pour baignoires en acier

Istruzioni di montaggio

Materiale insonorizzante Poresta® DIN 4109 per vasche da bagno in acciaio

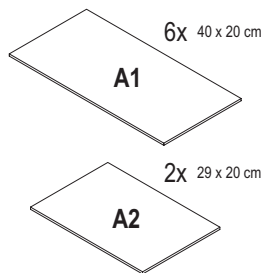

Poresta® Antidröhnmaten /
Silencing mats /
Antidreunmaten /
Matelas anti-vrombissants /
Stuoie antirombo

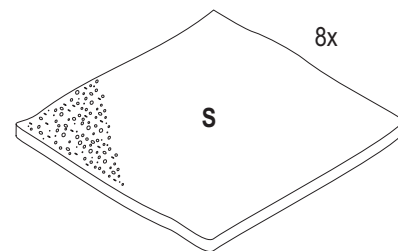

Poresta® Schalldämpfungsmatte /
Sound absorbing mat /
Geluidsisolatiemat /
Matelas insonorisant /
Stuoia insonorizzante



Poresta® Schallentkopplungsstreifen /
Antiresonant strip /
Geluidsisolatiestroken /
Bande d'isolation acoustique /
Fascia d'isolamento acustico



Poresta® Dämm- und Schutzband /
Insulating and protective strip /
Wandisolatieband /
Bande d'insonorisation et de protection /
Fascia d'insonorizzazione e di protezione



Befestigungsstifte /
Fastening pins /
Bevestigingspennen /
Chevilles de fixation /
Caviglie di fissaggio

Notes and further information see page 5 /
Referenties en meer informatie, zie pagina 5 /
Renseignnement et informations complémentaires, voir page 6 /
Riferimenti e ulteriori informazioni, vedere pagina 6

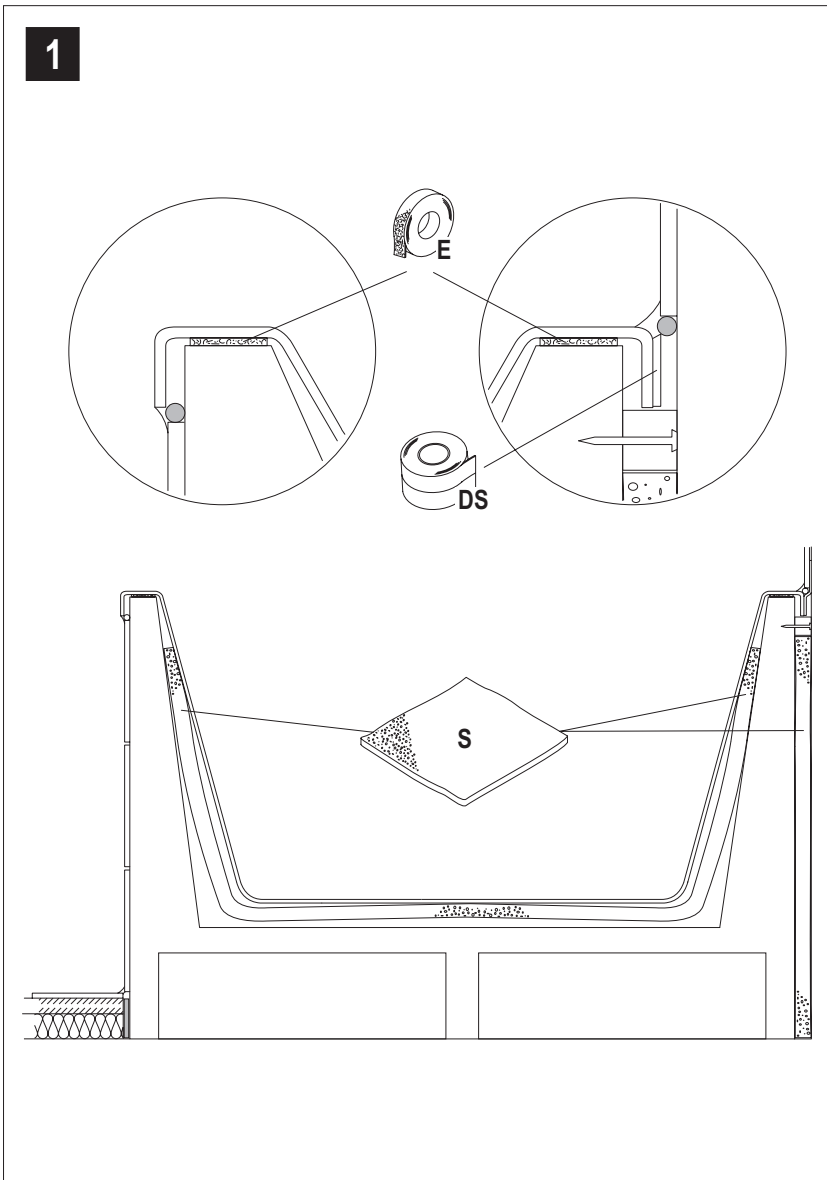

⚠ Die einschlägigen Verarbeitungsrichtlinien aller beteiligten Gewerke sind zu berücksichtigen.

⚠ Für die Verwendung des Schallschutzsets sind Schallprüfberichte nach DIN 4109 verfügbar. Zur Einhaltung der gemessenen Installationsschallpegel müssen die aufgeführten Poresta® Produkte fachgerecht verwendet werden.

⚠¹ Vor Verfugen der Duschwanne mit Silikon ist ein weiches Hinterfüllmaterial einzubringen.

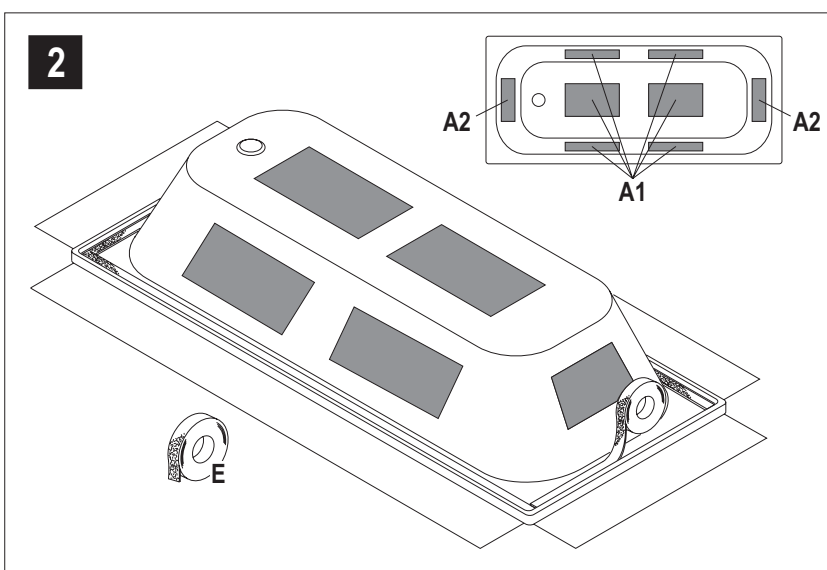

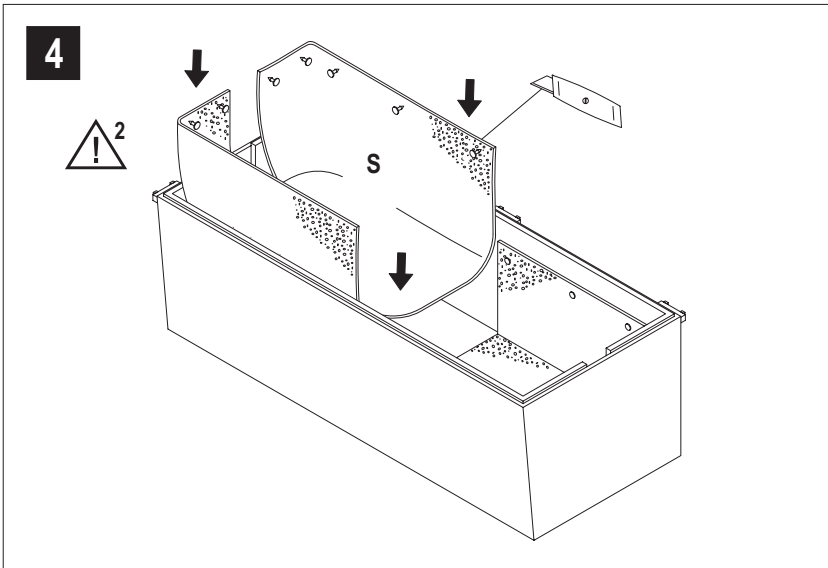
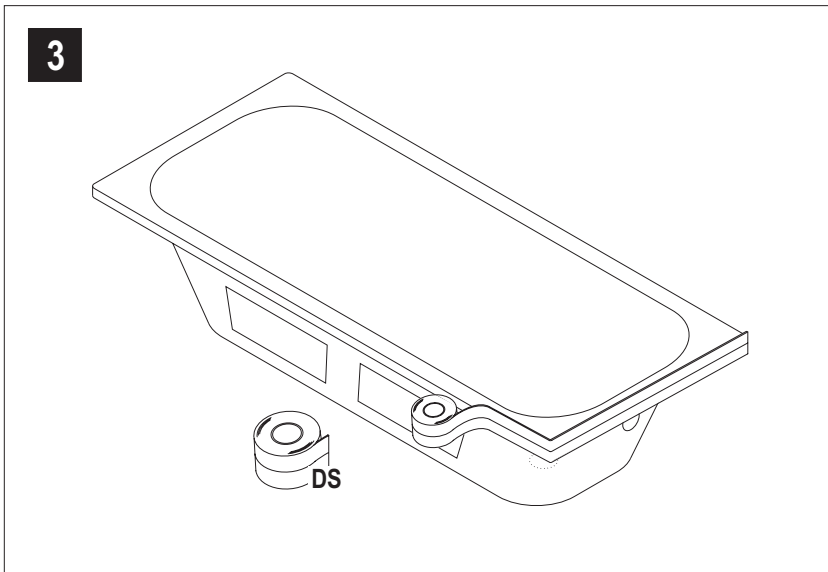

!² Die Schalldämmungsmatte einlagig an den inneren Seitenwänden des Wannenträgers 13 cm unterhalb des Randes feststecken. Die Befestigungsstifte erst durch die Schalldämmungsmatte stecken und danach am Wannenträger feststecken. Im Bodenbereich kann die Schalldämmungsmatte zweilagig überlappen.

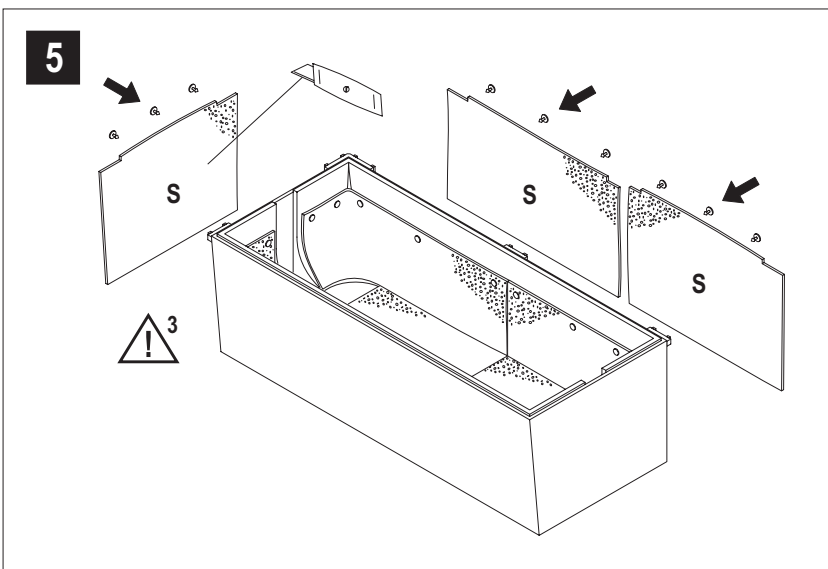

!³ Die Schalldämmungsmatte zuschneiden und einlagig an den hinteren Seitenwänden des Wannenträgers 2 cm unterhalb des Randes feststecken.

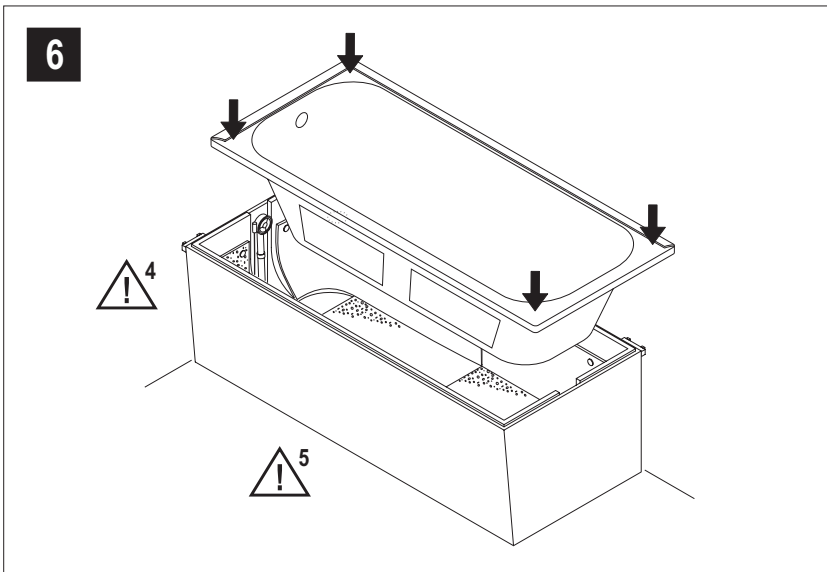





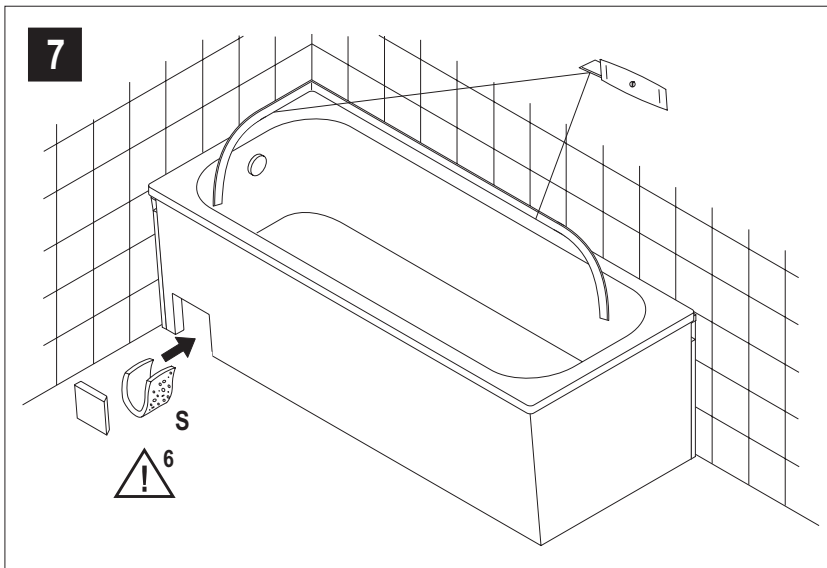



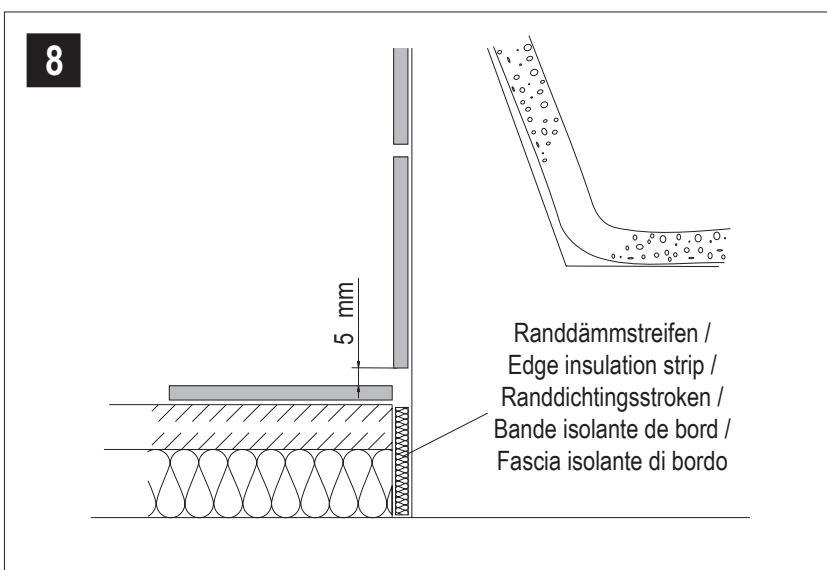







4 Die Badewanne darf nicht im Poresta® Badewannenträger kippen oder der Badewannenträger nach Einsetzen der Badewanne ausbeulen. Überprüfung mit Richtscheit, gegebenenfalls die Schalldämmungsmatte in den betroffenen Bereichen kleinflächig entfernen. Bei Badewannenträgern mit Verstellböden sind diese aus der Schalldämmungsmatte freizuschneiden.

















5 Der weitere Einbau des Poresta® Badewannenträgers, der Ablaufgarnitur und der Badewanne erfolgt gemäß der jeweiligen Einbauanleitung.



6 Vor Verschließen der Revisionsöffnung Reststücke der Schalldämmungsmatte in vorhandene Hohlräume einbringen.



-
-  The relevant processing guidelines of all trades involved must be observed.
-  Sound test certificates according to DIN 4109 are available for the use of the sound proofing set. The Poresta® products must be used expertly to observe the measured installation sound levels.
-  1 Before pointing the joints of the bath tub with silicone, a soft backfilling material is to be used.
-  2 Attach the sound absorbing mat at one layer at the inside walls of the tub carrier 13 cm beneath the edge. The fastening pins are at first put through the sound absorbing mat and then stuck into the tub carrier. In the bottom area the sound absorbing mat may overlap at two layers.
-  3 Cut to size sound absorbing mat and attach it at one layer to the rear side walls of the tub carrier 2 cm beneath the edge.
-  4 The bathtub may not wobble in the Poresta® bathtub supporting frame or the bathtub supporting frame must not bulge after the installation of the bathtub. Inspection by means of straight edge; remove small sections of the sound absorbing mat in the relevant areas, if necessary. For bathtub supporting frames with adjustable bottoms the same are to be cut off the sound absorbing mat.
-  5 The installation of the Poresta® bath tub carrier, the outlet fitting and the bath tub is effected according to the respective mounting instructions.
-  6 Place offcuts of the sound absorbing mat in the existing hollows before closing the inspection opening.
-  Met de betreffende verwerkingsrichtlijnen van alle betrokken leveranciers moet rekening worden gehouden.
-  Voor de toepassing van de isolatieset in verbinding met Poresta® drempelloze douchesystemen zijn certificaten volgens DIN 4109 beschikbaar. Om de mogelijke grenswaarden te bereiken, moeten de genoemde Poresta® producten vakkundig worden verwerkt.
-  1 Voor het afvoegen van de badkuip met siliconen moet zacht opvulmateriaal worden aangebracht.
-  2 De geluidsisolatiemat in één laag aan de binnenkant van de zijwanden van de badkuipdrager 13 cm onder de rand vaststeken. De bevestigingspennen eerst door de isolatiemat steken en daarna aan de badkuipdrager vaststeken. In de bodemsector kunnen de isolatiematten elkaar overlappen.
-  3 De geluidsisolatiemat op maat snijden en in één laag aan de achterliggende kant van de zijwanden van de badkuipdrager 2 cm onder de rand vaststeken.
-  4 De badkuip mag in de Poresta® badkuipdrager niet slingeren of de badkuipdrager na het inzetten van de badkuip niet uitbuilen. Controle met richtblok/richtlat, evt. geluidsdempingsmat op betroffen plaatsen gedeeltelijk verwijderen. Bij badkuipdragers met verstelbare bodems moeten deze uit de geluidsisolatiemat gesneden worden.
-  5 De inbouw van de Poresta® badkuipdrager, de afvoergarnituur en de badkuip gebeurt volgens de desbetreffende inbouwhandleiding.
-  6 Voor het sluiten van de revisie-opening reststukken van de geluidsisolatiemat in aanwezige holle ruimtes stoppen.

-  Les directives correspondantes de mise en oeuvre de tous les métiers participants sont à observer.
-  Pour l'utilisation du matériel d'insonorisation, des certificats de contrôle du bruit selon DIN 4109 sont disponibles. Pour obtenir les niveaux sonores d'installation mesurés, il est nécessaire d'effectuer la mise en oeuvre des produits Poresta® indiqués conformément aux règles de l'art.
-  1 Avant de procéder au jointoiment au moyen de silicone de la baignoire, il faut appliquer de la matière de remplissage molle.
-  2 Fixer le matelas insonorisant en une couche aux parois latérales intérieures du support de la baignoire, à 13 cm au-dessous du bord. Pousser d'abord les chevilles de fixation à travers le matelas insonorisant et puis les fixer au support de la baignoire. Au niveau du fond, le matelas insonorisant peut être placés à recouvrement formant ainsi deux couches.
-  3 Couper sur mesure le matelas insonorisant et le fixer en une couche sur les parois latérales postérieures du support de la baignoire, à 2 cm au-dessous du bord.
-  4 Après la mise en place de la baignoire, la baignoire doit avoir une position tout à fait stable sur le support de baignoire Poresta® ou le support de baignoire ne doit pas présenter de bosses. Procéder à un contrôle au moyen d'une règle et, le cas échéant, enlever le matelas insonorisant sur une surface réduite dans les zones concernées. En cas de supports de baignoires avec fond réglable, il faut couper une ouverture correspondante pour le fond dans le matelas insonorisant.
-  5 L'installation du support de baignoire Poresta®, de la robinetterie d'écoulement et de la baignoire doit s'effectuer conformément aux instructions de montage respectives.
-  6 Avant de fermer l'ouverture d'inspection, placer les bouts restants du matelas insonorisant dans les espaces vides existants.
-  Si deve osservare le istruzioni corrispondenti di lavorazione di tutti i mestieri partecipanti.
-  Per l'utilizzazione del materiale d'insonorizzazione sono disponibili certificati di controllo del rumore secondo DIN 4109. Per ottenere i livelli sonori d'installazione misurati è necessario di far attenzione alla messa in opera a regola d'arte dei prodotti Poresta® indicati.
-  1 Prima di procedere alla rabboccatura con silicone è necessario di applicare materiale morbido di riempimento.
-  2 La stuoia insonorizzante è da posare in uno strato e da fissare sulle pareti laterali interne del supporto della vasca, a 13 cm al di sotto del bordo. Prima le caviglie sono da configurare attraverso la stuoia insonorizzante e poi da fissare sul supporto della vasca. Sul fondo, la stuoia insonorizzante può essere posata con sovrapposizione a due strati.
-  3 La stuoia insonorizzante è da tagliare su misura e poi da posare in uno strato e da fissare sulle pareti laterali posteriori del supporto della vasca, a 2 cm al di sotto del bordo.
-  4 Dopo la posa la vasca da bagno non deve dondolare nel supporto di vasca Poresta® o il supporto di vasca non deve presentare rilievi. Procedere ad un controllo al regolo; rimuovere eventualmente la stuoia insonorizzante da una parte ridotta della superficie nelle zone interessate. In caso di supporti di vasca con fondi regolabili gli stessi devono essere tagliati dalla stuoia insonorizzante.
-  5 L'installazione del supporto di vasca Poresta®, della rubinetteria di scarico e della vasca da bagno è da eseguire in conformità alle istruzioni di montaggio rispettive.
-  6 Mettere i resti della stuoia insonorizzante nelle cavità esistenti prima di chiudere l'apertura di ispezione.