

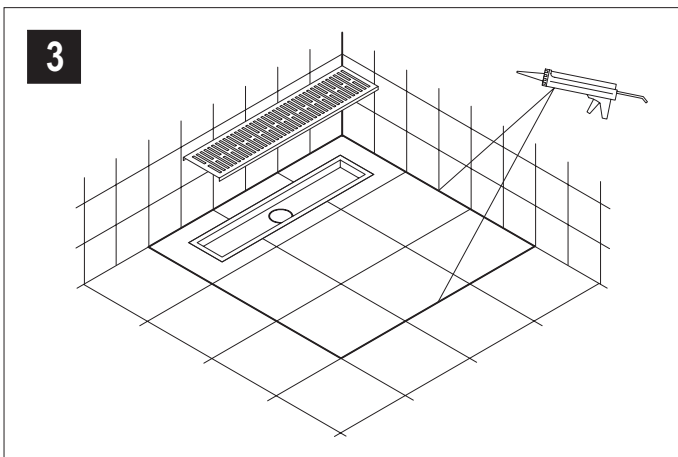

Einbauanleitung (Fliesenleger)
Mounting instruction (Tiler)
Montagehandleiding (Tegelzetter)
Instructions de montage (Carreleur)
Istruzioni di montaggio (Piastrellista)

Poresta® BFR Universalrinnenboard
 Poresta® BFR Universal Grooved Board
 Poresta® BFR universeel goot-board
 Lambris intérieur universel Poresta® BFR
 Piastra scanalata universale Poresta® BFR

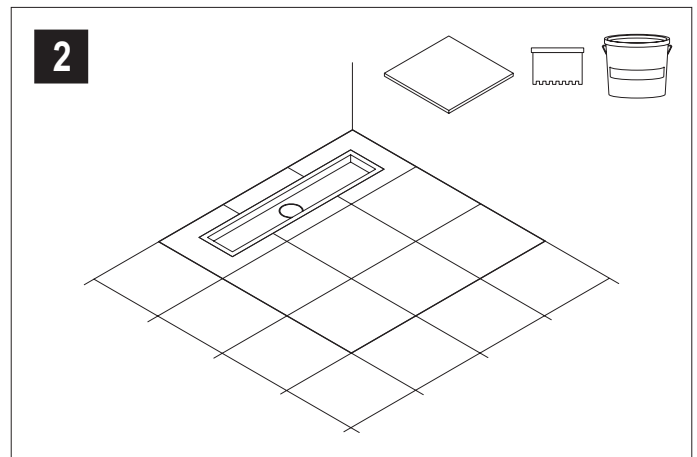

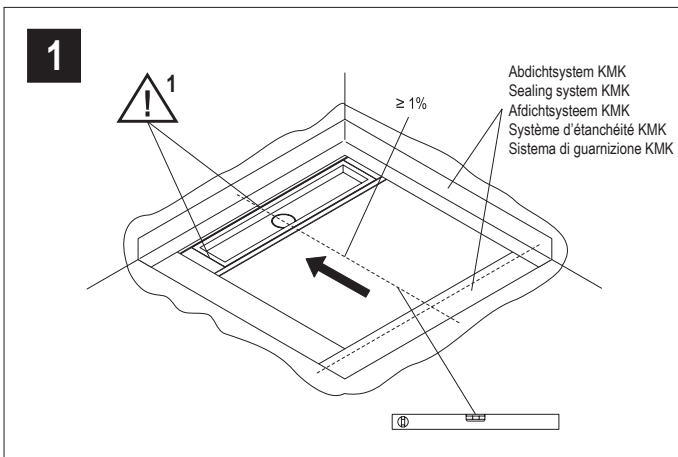

 Die einschlägigen Verarbeitungsrichtlinien aller beteiligten Gewerke sind zu berücksichtigen.

 Die Verarbeitungshinweise des Abdichtsystem KMK sind zu beachten.

 Das Abdichtset des Rinnen-Herstellers ist zu verwenden (nicht im Lieferumfang).







 The relevant processing guidelines of all trades involved must be observed.

 The processing guidelines of the KMK sealing system are to be observed.

 The sealing set of the groove manufacturer is to be used (not included in the scope of supply).

Einbauanleitung (Fliesenleger) Mounting instruction (Tiler) Montagehandleiding (Tegelzetter) Instructions de montage (Carreleur) Istruzioni di montaggio (Piastrellista)

Poresta® BFR Universalrinnenboard
Poresta® BFR Universal Grooved Board
Poresta® BFR universeel goot-board
Lambris intérieur universel Poresta® BFR
Piastra scanalata universale Poresta® BFR

-  Met de betreffende toepassingsrichtlijnen van alle betroffen onderdelen moet rekening worden gehouden.
-  Met de betreffende toepassingsrichtlijnen van afdichtstysteem KMK moet rekening worden gehouden.
-  De afdichtset van de afvoefabrikant moet worden toegepast (niet in levering inbegrepen).
-  Les directives correspondantes de mise en oeuvre de tous les métiers participants sont à observer.
-  Il faut respecter les instructions de mise en oeuvre du système d'étanchéité KMK.
-  Il faut utiliser l'ensemble de matériel d'étanchéité du fabricant du conduit (pas compris dans la fourniture).
-  Si deve osservare le direttive corrispondenti di lavorazione di tutti i mestieri partecipanti.
-  Si deve osservare le istruzioni di lavorazione del sistema di guarnizione KMK.
-  Si deve utilizzare il materiale di guarnizione del fabbricante del condotto di scolo (non compreso nella fornitura).

Empfohlenes Zubehör / Recommended accessories /
Aanbevolen toebehoren / Accessoires recommandés /
Accessori raccomandati:



Fliesenkleber / Tile adhesive / Tegellijm /
Colle pour carreaux / Collante per piastrelle



illbruck Abdichtsystem KMK / Sealing system KMK /
Afdichtstysteem KMK / Système d'étanchéité KMK /
Sistema di guarnizione KMK



Poresta® BF KMK Dichtband / Sealing tape / Afdichtings-
band / Bande isolante / Fascia isolante



Poresta® BF KMK Dichtband-Innenecke / Sealing tape
interior corner / Afdichtingsband-binnenliggende hoek /
Bande isolante pour coin intérieur / Fascia isolante per
angolo interno

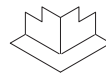

Poresta® BF KMK Dichtband-Außenecke / Sealing tape
exterior corner / Afdichtingsband-buitenliggende hoek /
Bande isolante pour coin extérieur / Fascia isolante per
angolo esterno



Silikon / Silicone / Siliconen / Silicone / Silicone